

Electric cylinders series 1800



Founded in 1976, **Pneumax S.p.A.** is today one of the leading, international manufacturers of components and systems for industrial automation. It is at the head of a group comprised of 21 companies, with over 660 employees worldwide. Ongoing investment in research and development has allowed **Pneumax** to continually expand its range of standard products and customised solutions, adding to the well-established pneumatic technology, the electrical actuation and fluid control components.

The possibility to provide various technologies to optimise every single client application is in fact the main objective of our company, making us the ideal, strategic partner.

What defines us is the “Pneumax Business Attitude”, born out of the capacity to combine sectorial, technological and applicative skills through client collaboration with our Sector Business Specialists and Product Specialists. This represents the true distinguishing factor that **Pneumax** offers.

The **Pneumax** range of products for electrical actuation includes axes and electrical cylinders with their related brushless motors and drivers.

Both the cylinders and the axes can be provided without a motor or with Siemens motorisation, a consolidated partner of **Pneumax**.

A vast range of accessories and fixing plates ensure the maximum flexibility in the realisation of combined multi-axes gantry solutions.



Electrical cylinders with linear or parallel motors
Electrical axes with recirculating ball bearing guides and belt drive
Brushless Servo motors

Drivers

- Ø 32, 40, 50, 63
- Fixing interface ISO 15552
- Versions with linear or parallel motors
- SIEMENS brushless motors
- IP Rating IP65
- Anti-rotating piston
- Adapted for use with magnetic sensors
- A vast range of accessories and motor fixing interfaces



General	pag. 2
Characteristics	pag. 3
Codes	pag. 4 - 6
Overall dimensions	pag. 7 - 9
Technical data	pag. 10 - 14
Fixing	pag. 15 - 27
Sensors	pag. 28 and 29



General

The Series 1800 Electric cylinders offer additional functions to that of a standard pneumatic cylinder, with the possibility to totally manage the complete working cycle, with control over acceleration and deceleration and the ability stop in mid position with precision and repeatability to fractions of a millimetre.

The actuators are available four sizes, 32-40-50-63, with in-line or parallel mounted electric motors with a fixing interface according to ISO 15552 standard.

The motor drives a ball screw transmission that converts the motors rotary motion into a linear motion.

The internal piston is non-rotating with built in calibrated slides to reduce any torsional backlash of the piston rod and to obtain optimal precision for positioning.

The actuators are fitted with magnetic pistons for use with external sensors or external linear position transducers.

It is possible to access the ball screw through a hole in the barrel for the purpose of lubrication.

IP Rating: cylinder (Ip65)

Motors: brushless SIEMENS (Ip65), relativ encoder (100W, 400W, 750W, 1000W, 1500W,2000W)

Versions with brake and positioning encoders are available upon request.

In the event of the customer wanting to use they're own electric motor, Pneumax can provide the required assembly kits upon request.

Driver: Siemens 220 ÷ 240V 1AC/3AC

A version for multi-axis interpolation is available upon request.

The moving direction of the piston rod depends on the direction of rotating ball screw. (see drawings below).

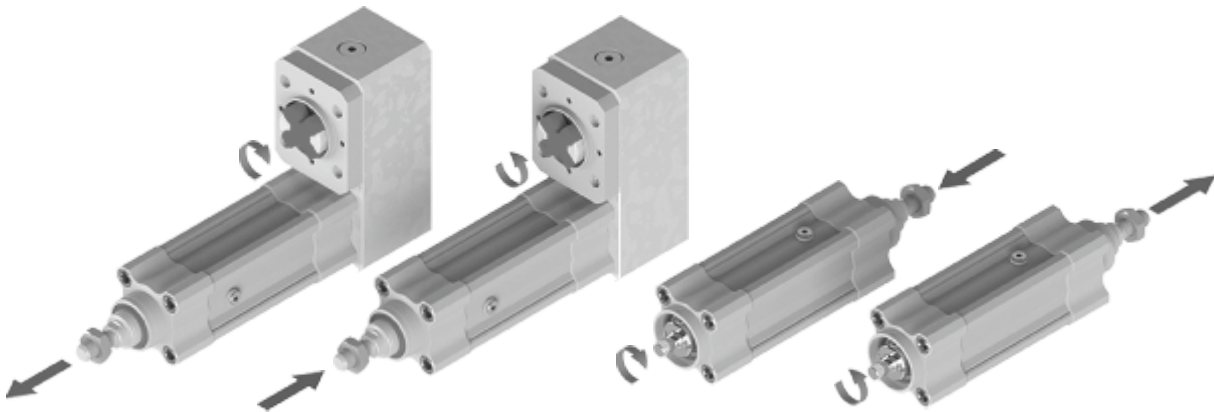



Construction characteristics

Standard	ISO 15552 (only for fixing interface)
Rod version	non rotating rod
Transmission device	ball screw device
Rod	stainless steel
Head nut	stainless steel
Heads	anodized aluminum
Barrel	anodized aluminum

Operational characteristics

Characteristics	U.M	Value
Working temperature	°C	0 / +60
Storage temperature	°C	-20 / +60
IP Rating	-	IP65
Air relative humidity	%	90% (condensation not admitted)
Out of control impact at the end of the stroke	-	NOT ADMITTED (recommended addition to stroke min. 30mm)
Magnetic piston	-	yes

Technical characteristics

Description	U.M	Size 32			Size 40			Size 50			Size 63			
Ball screw pitch	mm	5	10	12	5	10	16	5	10	20	5	10	25	
Ball screw diameter	mm	12			16			20			25			
Max torque admitted	In-line motor	Nm	1,8	3,0	4,1	5,8	7,0	6,1	7,8	13,1	22,0	12,2	22,6	34,3
	Parallel motor										15,0		20,0	20,0
Friction torque	Nm	0,1			0,2			0,3			0,5			
Radial load admitted	N	(see the graphs in the Technical data section)						(see the graphs in the Technical data section)						
Coefficient of dynamic axial load	N	4.700	4.700	5.450	15.200	9.600	9.600	17.650	18.300	12.350	23.500	27.150	13.600	
Admitted axial load	N	1.950	1.650	1.900	6.550	3.900	2.150	8.750	7.350	6.200	13.750	12.750	7.750	
Efficiency	-	0,9												
Max. stroke	mm	800						1000			1200			
Min. stroke	mm	30												
Max. admitted rotary speed	rpm	(see the graphs in the Technical data section)						(see the graphs in the Technical data section)						
Max. admitted linear speed	m/s	(see the graphs in the Technical data section)						(see the graphs in the Technical data section)						
Max. admitted acceleration	mm/s ²	5	13	15	4	12	20	4	10	20	4	10	20	
Repetition accuracy	mm	±0.015												
Max. axial play (backlash)	mm	≤0,02			≤0,04			≤0,04	≤0,05	≤0,04	≤0,04	≤0,05	≤0,04	
Max. torsional backlash of piston rod	(°)	±0.25												



The following combinations are available to order:

Cylinder which can be assembled with an IN-LINE motor.	Cylinder which can be assembled with a PARALLEL mounted motor	Cylinder with IN-LINE motor	Cylinder with PARALLEL motor
Motors	Drivers, filters, cables		Motors fixing kits (in line or parallel version)
Fixing and accessories			

Cylinder ordering codes (with or without motor)



Motor Assembly Position		Size	Stroke (mm)*	Ball screw pitch	Motor			
A	IN-LINE position	A 32	Size 32 (max. 800)	A pitch 5	0000	Without motor		
B	PARALLEL position (transmission ratio: 1:1)	B 40	Size 40 (max. 800)	B pitch 10	BRUSHLESS SIEMENS			
		C 50	Size 50 (max. 1000)	C pitch 12 (only Ø32)	200 ÷ 240V 3AC - IP65 - SIEMENS	B001	motor cod. 1800B0400801 0,32 Nm - 100W	available on size 32 and 40
		D 63	Size 63 (max. 1200)	D pitch 16 (only Ø40)		B002	motor cod. 1800B0601401 1,27 Nm - 400W	available on size 32, 40 and 50
				E pitch 20 (only Ø50)		B003	motor cod. 1800B0801900 2,39 Nm - 750W	available on size 40, 50 and 63
				F pitch 25 (only Ø63)		B004	motor cod. 1800B0801901 3,18 Nm - 1000W	available on size 50 and 63
						B005	motor cod. 1800B1001900 4,78 Nm - 1500W	available on size 50 and 63
						B006	motor cod. 1800B1001901 6,37 Nm - 2000W	available on size 63

*** Stroke definition**

To avoid damage, it is important to prevent collision at the end of the stroke of the piston. Therefore, add an additional 30mm to the required stroke length.

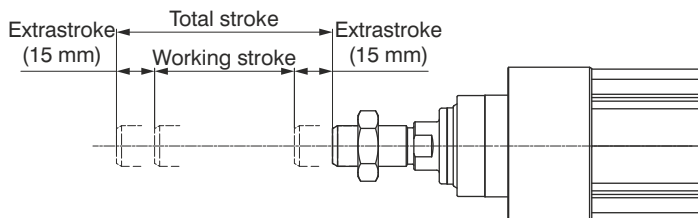

SIEMENS motors with brake and absolute encoder are available upon request.



BRUSHLESS SIEMENS MOTORS with incremental encoder without brake (Motors with absolute encoders or brake are also available upon request)							
Ordering code	1800B0400801	1800B0601401	1800B0801900	1800B0801901	1800B1001900	1800B1001901	
Torque	rated	0,32 Nm	1,27 Nm	2,39 Nm	3,18 Nm	4,78 Nm	6,37 Nm
	maximum	0,96 Nm	3,82 Nm	7,20 Nm	9,54 Nm	14,30 Nm	19,10 Nm
Usable cylinders sizes	32 and 40	32, 40 and 50	40, 50 and 63	50 and 63		63	
rpm	5000 max. / 3000 rated						
Rated voltage	200-240V 1AC/3AC			200-240V 3AC			
Rated power	100 W	400 W	750 W	1.000 W	1.500 W	2.000 W	
Moment of inertia (10 ⁻⁴ Kgm ²)	0,052	0,351	0,897	1,15	2,04	2,62	
Temperature	storage	-20°C +65°C (-4°F +149°F)					
	operation	0°C +40°C (-32°F +104°F)					
Thermal class	B (130°C/266°F)						
Relative atmospheric humidity (storage and operation)	90% to 30°C (86°F) (no condensation)						
IP Rating	IP65						
Weight (g)	630	1.460	2.800	3.390	5.350	6.560	



SERVO DRIVER SIEMENS							
Ordering code	1800AZ0001	1800AZ0003	1800AZ0004	1800AZ0005	1800AZ0006	1800AZ0007	
Usable motor	1800B0400801	1800B0601401	1800B0801900	1800B0801901	1800B1001900	1800B1001901	
Line frequency	50Hz / 60Hz ±10%						
Communication	n°2 PROFINET communication with a PLC (RJ45)						
Max. motor power	100W	400W	750W	1000W	1500W	2000W	
Frame size	FSA	FSB	FSC	FSD			
Dimensions	Height	45mm	55mm	80mm	95mm		
	Width	170mm					
	Depth	170mm		195mm			
Output current	rated	1,2A	2,6A	4,7A	6,3A	10,6A	11,6A
	max.	3,6A	7,8A	14,1A	18,9A	31,8A	34,8A
Line supply voltage	200 ÷ 240V 1AC/3AC (-15 %/+10 %)			200 ÷ 240V 3AC (-15 %/+10 %)			
Line capacity	single-phase 1AC	0,5kVA	1,2kVA	2kVA	-	-	-
	three-phase 3AC	0,5kVA	1,1kVA	1,9kVA	2,7kVA	4,2kVA	4,6kVA
Cooling	Natural cooling			Fan cooling			
Weight (g)	1.100	1.200	2.000	2.500			
USB interfaces	mini USB						
Digital outputs	4 inputs, NPN/PNP; 2 outputs, NPN/PNP						
SD card slot	micro Sd						
Safety functions	STO (safe torque off) SIL2						

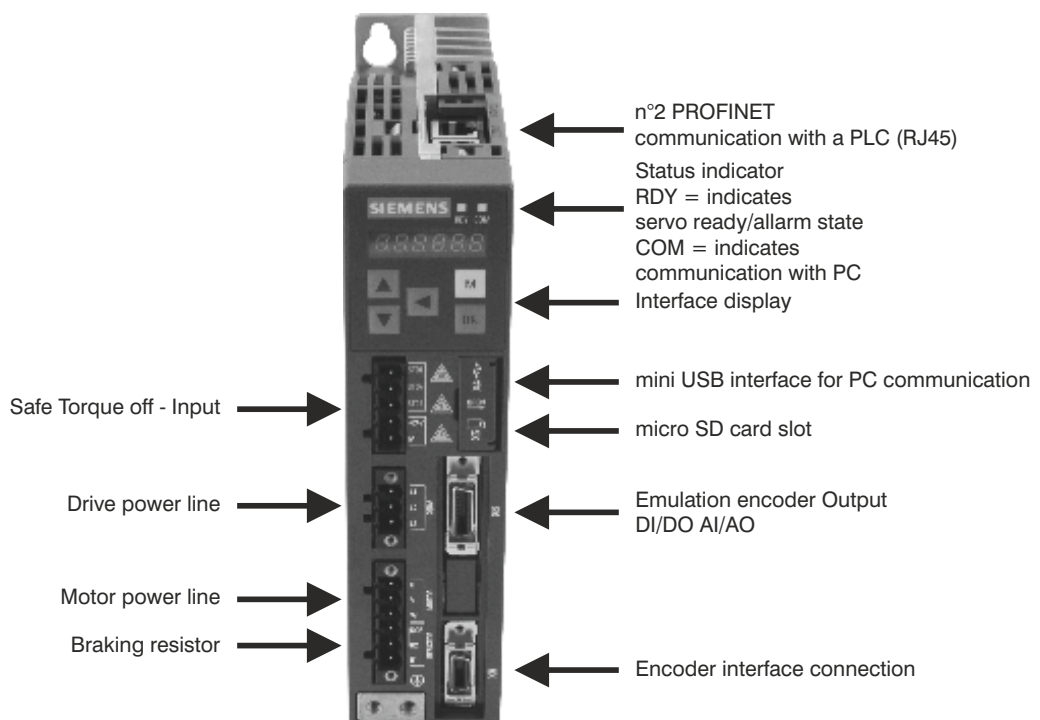



ELECTRICAL IMPLEMENTATION



FILTER						
Ordering code	1800FT0001 (for 3AC)			1800FT0002 (for 3AC)		
	1800FT0003 (for 1AC)			/		
Usable motor	1800B0400801	1800B0601401	1800B0801900	1800B0801901	1800B1001900	1800B1001901



3Mtr Motor Cable ORANGE (5, 7, 10, 15 and 20Mtr cables are available upon request)						
Ordering code	1800CM000103			1800CM000203		
	Usable motor	1800B0400801	1800B0601401	1800B0801900	1800B0801901	1800B1001900



3Mtr Encoder Cable GREEN (5, 7, 10, 15 and 20Mtr cables are available upon request)						
Ordering code	1800CE000103			1800CE000203		
	Usable motor	1800B0400801	1800B0601401	1800B0801900	1800B0801901	1800B1001900

SIEMENS motor fixing KITS code

Cylinder size	MOTOR ordering code	Fixing KITS ordering code			
		IN LINE version	Weight (g)	PARALLEL version	Weight (g)
32	1800B0400801	18KL0001	250	18KP0001	200
	1800B0601401	18KL0002	290	18KP0002	240
40	1800B0400801	18KL0003	320	18KP0001	200
	1800B0601401	18KL0004	360	18KP0002	240
	1800B0801900	18KL0005	510	18KP0003	390
50	1800B0601401	18KL0006	517	18KP0004	485
	1800B0801900	18KL0007	890	18KP0005	655
	1800B0801901	18KL0007	890	18KP0005	655
	1800B1001900	18KL0008	1390	18KP0006	1150
63	1800B0801900	18KL0009	1090	18KP0005	655
	1800B0801901	18KL0009	1090	18KP0005	655
	1800B1001900	18KL0010	1590	18KP0006	1150
	1800B1001901	18KL0010	1590	18KP0006	1150



In the event of the customer wanting to use they're own motor, assembly kits for different brands of motor are available upon request. Please complete the table below and contact our technical office.

ØA	
A1	
A2	
ØB	
B1	
ØD	
ØD1	
D2	
E	
EE	

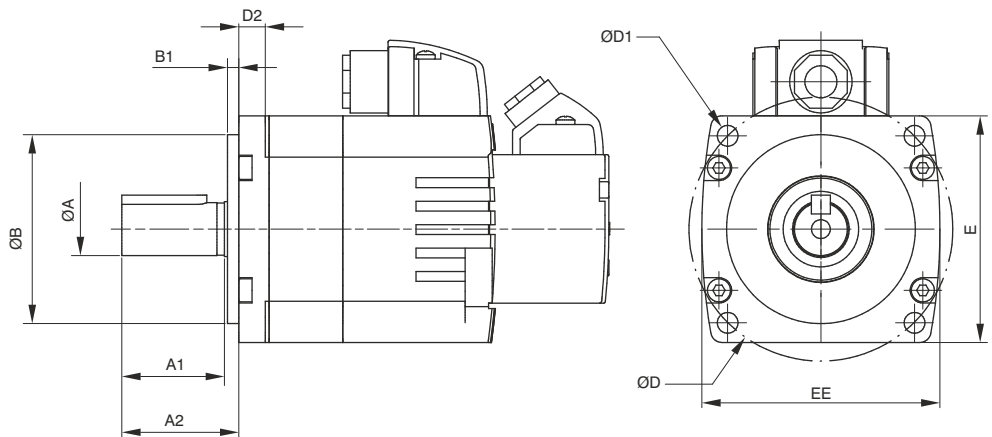

Cylinder dimensions without motor

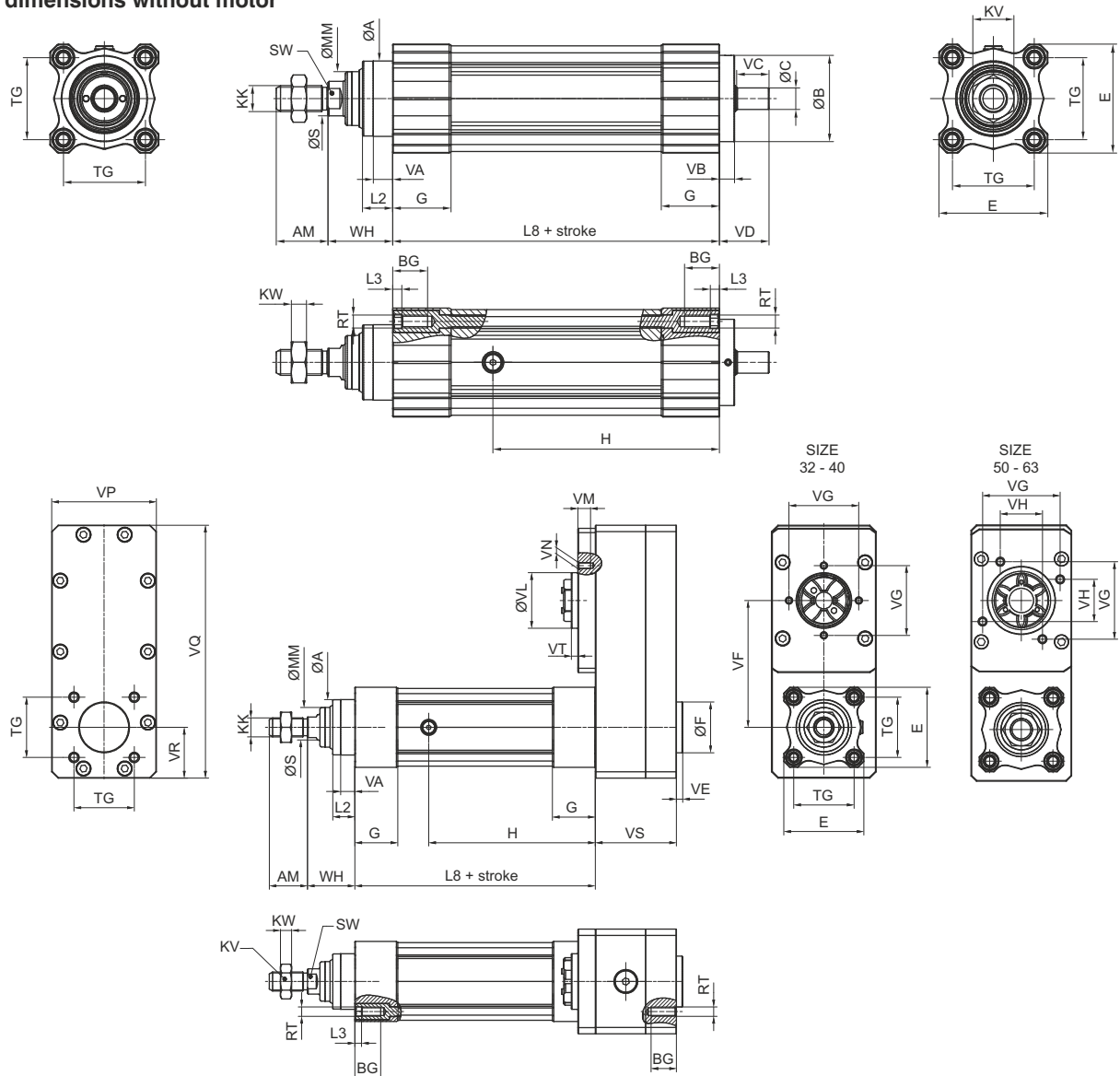

ELECTRICAL IMPLEMENTATION

Size	A	AM	B	BG	C	E	F	G	H	KK	KV	KW	L2	L3	L8	MM	RT	S	SW
32	30	22	34	16	8	45	30	27	86,75	M10x1,25	17	6	12	4	130,5	20	M6	14	12
40	35	24	40	16	10	50,5	35	27	105	M12x1,25	19	7	14	4	151,5	25	M6	16	13
50	40	32	50	18	12	62	40	33	118,75	M16x1,5	24	8	20	5	175	30	M8	19	17
63	45	32	60	18	15	72	45	33	126,75	M16x1,5	24	8	20	5	189	32	M8	19	17

Size	TG	VA	VB	VC	VD	VE	VF	VG	VH	VL	VM	VN	VP	VQ	VR	VS	VT	WH
32	32,5	8	7	12	20	4	60	44	/	35	8	M4	53	121	26,5	50,2	4	26
40	38	9	7	15	23	4	80	44	/	35	8	M4	66	159,5	32	51,2	4	30
50	46,5	9	9	18	28	4	95	57	31	50	9	M6	74	188,5	38	67,2	9	37
63	56,5	9	9	22,5	32,5	4	104	57	31	50	9	M6	86	209	43	67	9	37

In-line version weight (g)			
Size	0 Stroke		weight every mm
	Pitch	g	
32	5	744	3,2
	10	637	
	12	734	
40	5	1036	4,7
	10	1056	
	16	996	
50	5	1775	7
	10	1817	
	20	1775	
63	5	2499	8,7
	10	2600	
	25	2559	

Parallel version weight (g)			
Size	0 Stroke		weight every mm
	Pitch	g	
32	5	1526	3,2
	10	1419	
	12	1516	
40	5	2310	4,7
	10	2330	
	16	2270	
50	5	3870	7
	10	3912	
	20	3870	
63	5	5132	8,7
	10	5233	
	25	5192	

Cylinder dimensions with BRUSHLESS SIEMENS motor

Motors with power <1500W

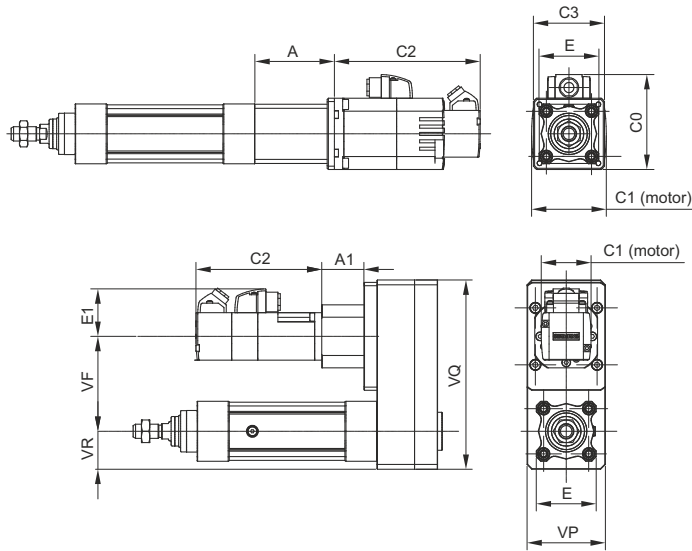

Motors with power ≥1500W

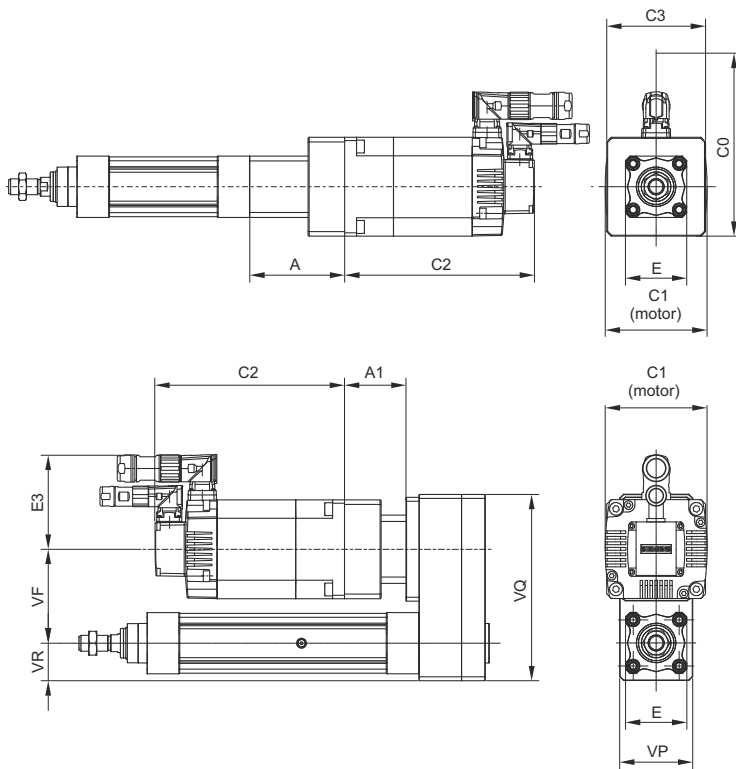

Cylinders weight + Motors (g)

Size	Motor	Pitch	0 Stroke		Weight every mm (g)
			In-line version (g)	Parallel version (g)	
32	0,32 Nm	5	1624	2356	3,2
	100W	10	1517	2249	
	1800B0400801	12	1614	2346	
	1,27 Nm	5	2494	3226	
	400W	10	2387	3119	
40	1800B0601401	12	2484	3216	4,7
	0,32 Nm	5	1986	3140	
	100W	10	2006	3160	
	1800B0400801	16	1946	3100	
	1,27 Nm	5	2856	4010	
	400W	10	2876	4030	
	1800B0601401	16	2816	3970	
50	2,39 Nm	5	4346	5500	7
	750W	10	4366	5520	
	1800B0801900	16	4306	5460	
	1,27 Nm	5	3752	5815	
	400W	10	3794	5857	
	1800B0601401	20	3752	5815	
	2,39 Nm	5	5465	7325	
	750W	10	5507	7367	
	1800B0801900	20	5465	7325	
	3,18 Nm	5	6055	7915	
	1000W	10	6097	7957	
63	1800B0801901	20	6055	7915	8,7
	4,78 Nm	5	8515	10370	
	1500W	10	8557	10412	
	1800B1001900	20	8515	10370	
	2,39 Nm	5	6389	8587	
	750W	10	6490	8688	
	1800B0801900	25	6449	8647	
	3,18 Nm	5	6979	9177	
	1000W	10	7080	9278	
	1800B0801901	25	7039	9237	
	4,78 Nm	5	9439	11632	
1500W	10	9540	11733		
63	1800B1001900	25	9499	11692	8,7
	6,37 Nm	5	10649	12842	
	2000W	10	10750	12943	
	1800B1001901	25	10709	12902	
	1800B1001901	25	10709	12902	

Size	Motor	A	A1	C0	C1	C2	C3	E	E1	E3	VF	VP	VQ	VR
32	cod. 1800B0400801 (0,32 Nm - 100W)	58	35	62,5	42	106	45	45	40	/	60	53	121	26,5
	cod. 1800B0601401 (1,27 Nm - 400W)	64	41,5	80	63	123	60	45	50	/	60	53	121	26,5
40	cod. 1800B0400801 (0,32 Nm - 100W)	61	35	65	40	106	50	50,5	40	/	80	66	159,5	32
	cod. 1800B0601401 (1,27 Nm - 400W)	67	41,5	80	63	123	60	50,5	50	/	80	66	159,5	32
	cod. 1800B0801900 (2,39 Nm - 750W)	73	47,5	100	83	139	80	50,5	60	/	80	66	159,5	32
50	cod. 1800B0601401 (1,27 Nm - 400W)	72	46	81	63	123	62	62	50	/	95	74	188,5	38
	cod. 1800B0801900 (2,39 Nm - 750W)	86	52	100	83	139	80	62	60	/	95	74	188,5	38
	cod. 1800B0801901 (3,18 Nm - 1000W)	86	52	100	83	159	80	62	60	/	95	74	188,5	38
	cod. 1800B1001900 (4,78 Nm - 1500W)	96	62	171	103	192	100	62	/	98	95	74	188,5	38
63	cod. 1800B0801900 (2,39 Nm - 750W)	86	52	100	83	139	80	72	60	/	104	86	209	43
	cod. 1800B0801901 (3,18 Nm - 1000W)	86	52	100	83	159	80	72	60	/	104	86	209	43
	cod. 1800B1001900 (4,78 Nm - 1500W)	96	62	171	103	192	100	72	/	98	104	86	209	43
	cod. 1800B1001901 (6,37 Nm - 2000W)	96	62	171	103	216	100	72	/	98	104	86	209	43
	cod. 1800B1001901 (6,37 Nm - 2000W)	96	62	171	103	216	100	72	/	98	104	86	209	43

ELECTRICAL IMPLEMENTATION

BRUSHLESS SIEMENS motors dimensions

Motors with power < 1500W

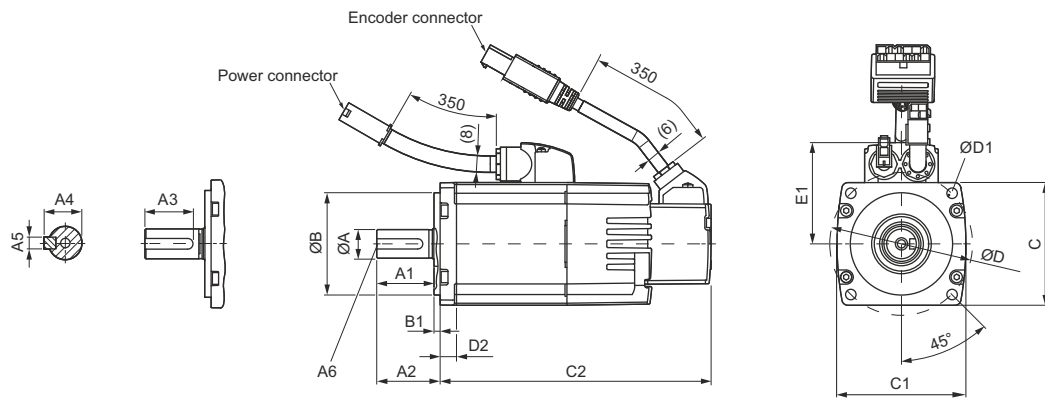

Motors with power ≥ 1500W

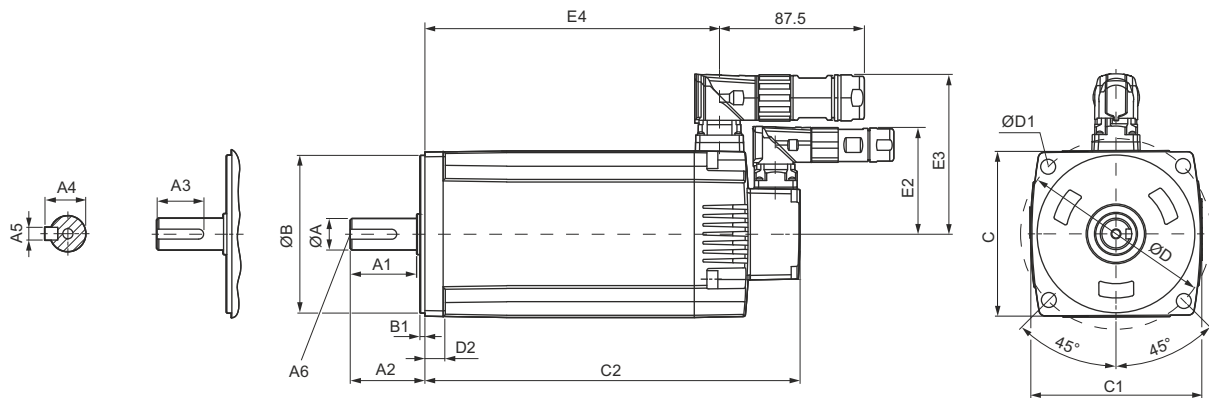

ELECTRICAL IMPLEMENTATION

	Ordering codes					
	1800B0400801	1800B0601401	1800B0801900	1800B0801901	1800B1001900	1800B1001901
Rated torque	0,32 Nm	1,27 Nm	2,39 Nm	3,18 Nm	4,78 Nm	6,37 Nm
Power	100 W	400 W	750 W	1.000 W	1.500 W	2.000 W
ØA	8	14	19	19	19	19
A1	22	26	30	30	40	40
A2	25	31	35	35	45	45
A3	17,5	22,5	28	28	28	28
A4	9	16	21,5	21,5	21,5	21,5
A5	3	5	6	6	6	6
A6	M3x8	M4x15	M6x16	M6x16	M6x16	M6x16
ØB	30	50	70	70	95	95
B1	2,5	3	3	3	3	3
C	40	60	80	80	100	100
C1	42	63	83	83	103	103
C2	106	123	139	159	192	216
ØD	Ø46	Ø70	Ø90	Ø90	Ø115	Ø115
ØD1	4,5	5,5	7	7	9	9
D2	6	8	8	8	12	12
E1	40	50	60	60	/	/
E2	/	/	/	/	65,5	65,5
E3	/	/	/	/	98	98
E4	/	/	/	/	143,5	167,5
Weight (g)	630	1460	2800	3390	5350	6560



Axial load admissible as a function of stroke

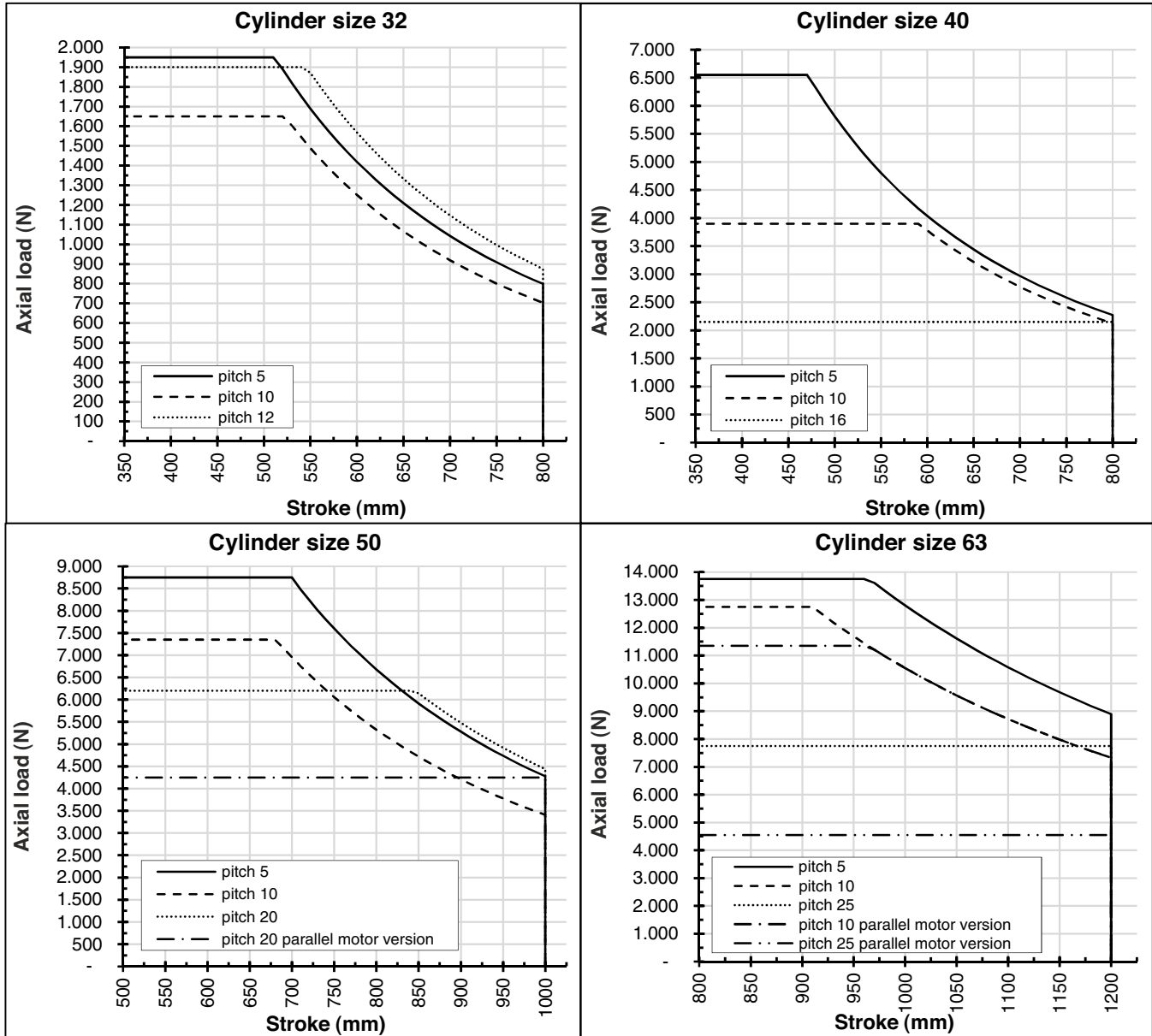

Radial load generated by the piston rod according to the stroke

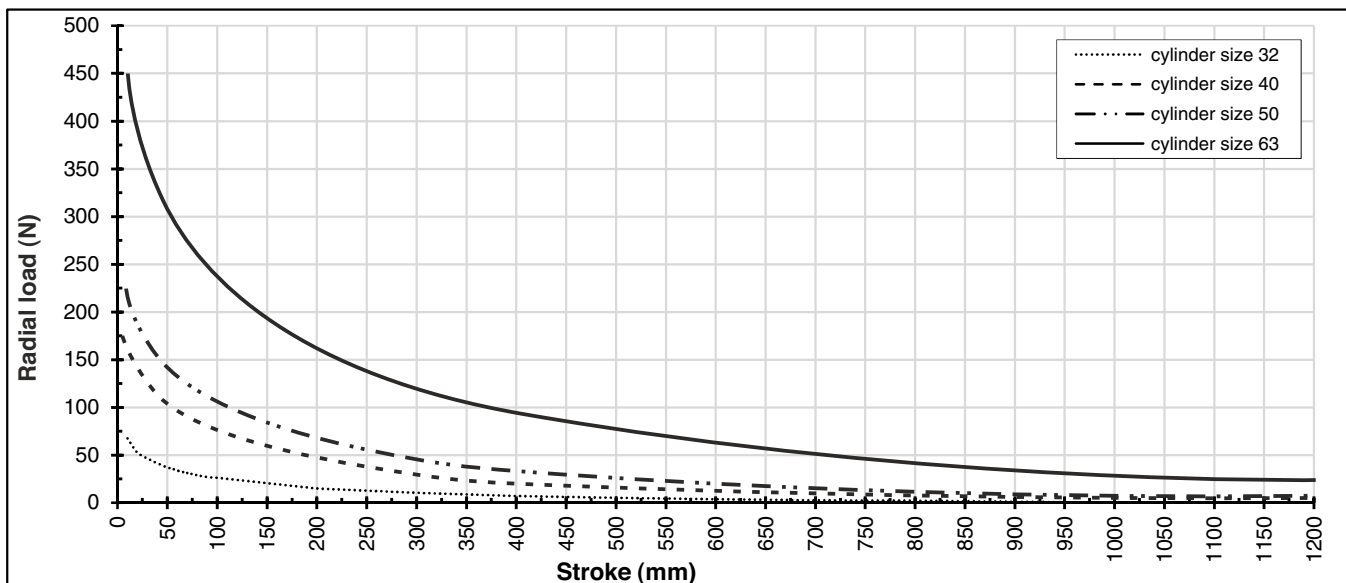



Maximum RPM subject to stroke

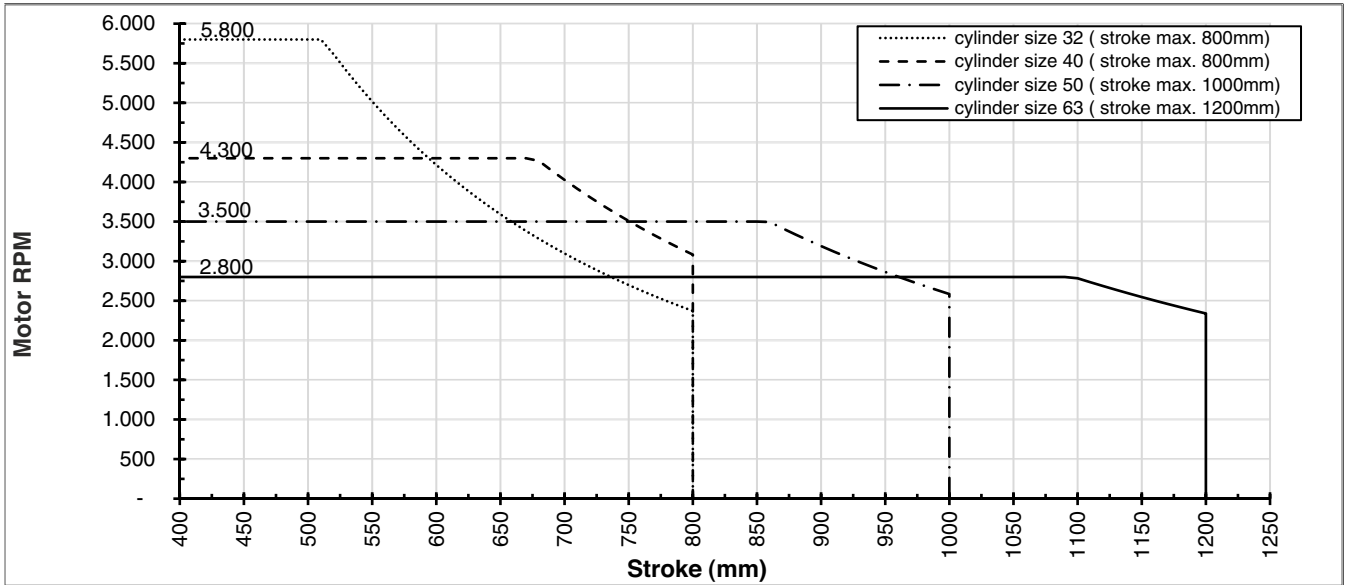

Speed: According to Motor (RPM)

Please note: Take in consideration the maximum number of revolutions shown in the previous graph.

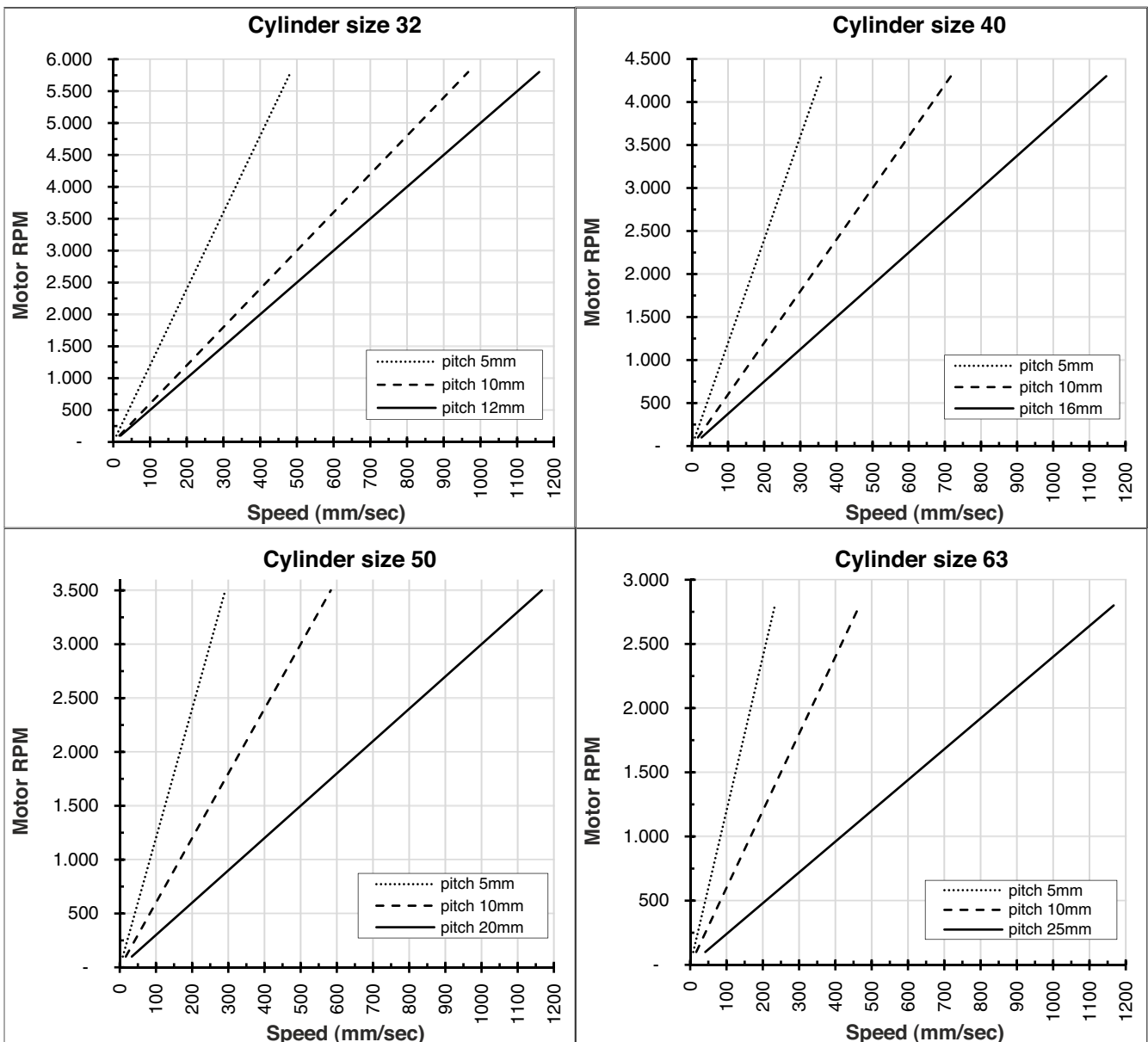



Torque curve characteristics of the BRUSHLESS SIEMENS motor

Power Supply Voltage: 220 VAC

Torque values below the rated torque line are continuously rated.

Torque values below the maximum torque line but above the rated torque line are momentary values not continuous.

ELECTRICAL IMPLEMENTATION

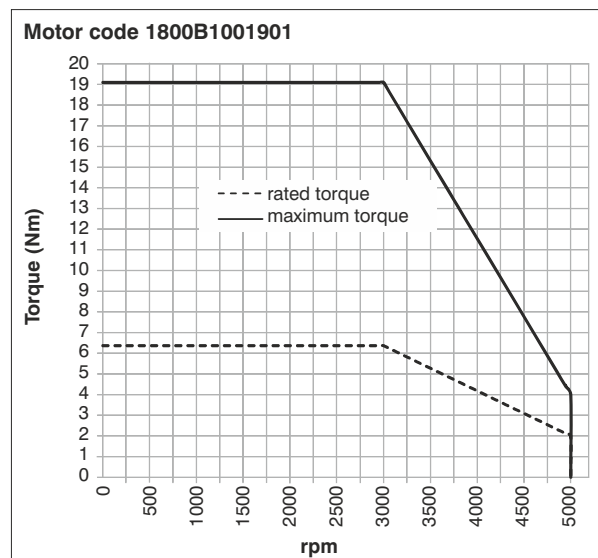
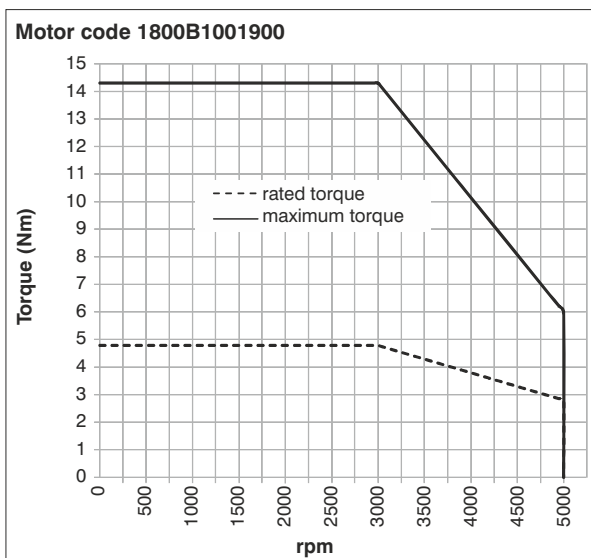
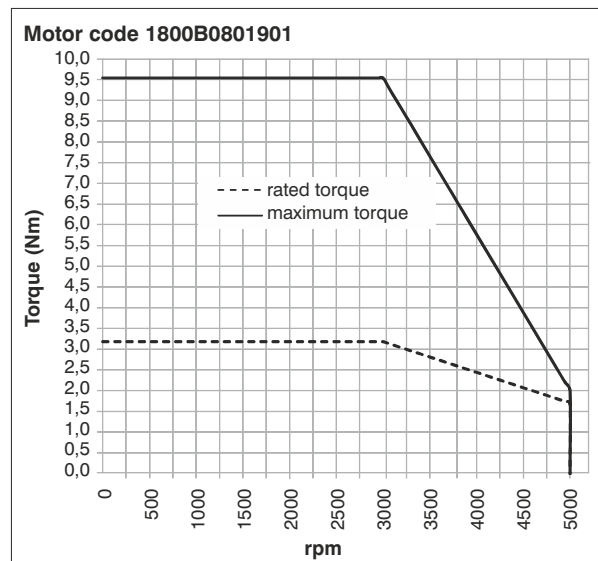
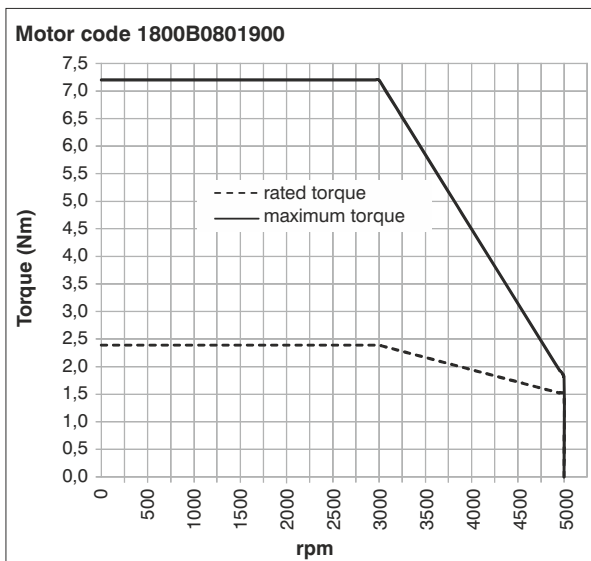
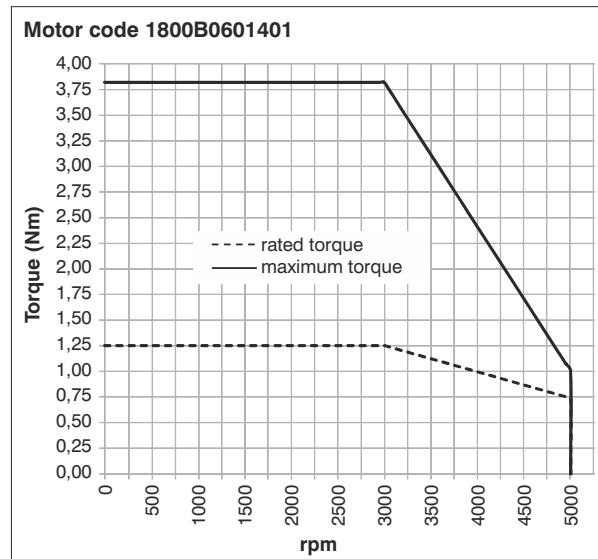
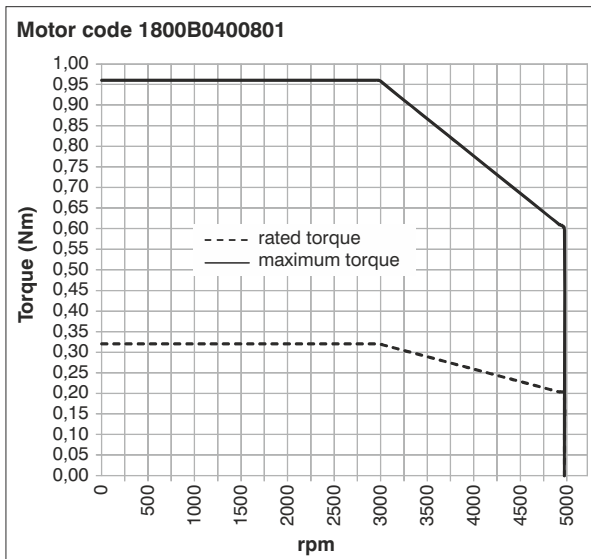

Cylinder thrust according to the motor torque

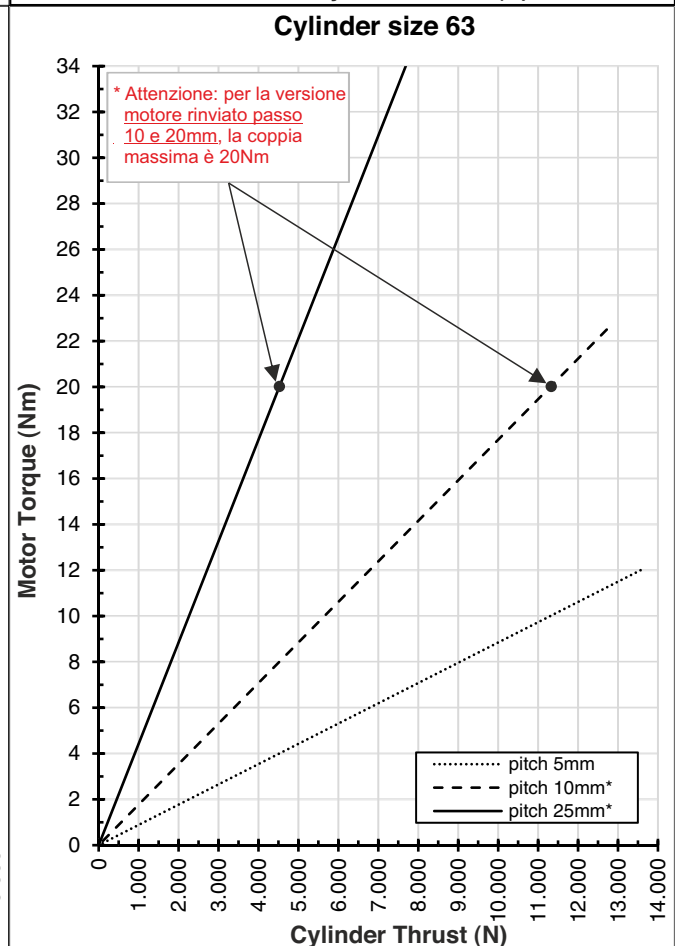
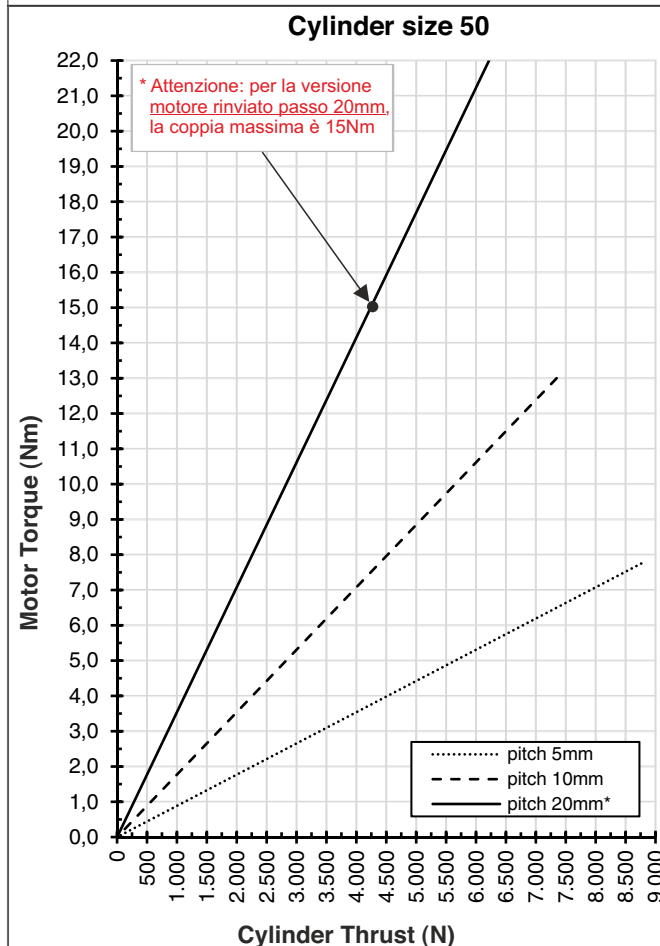
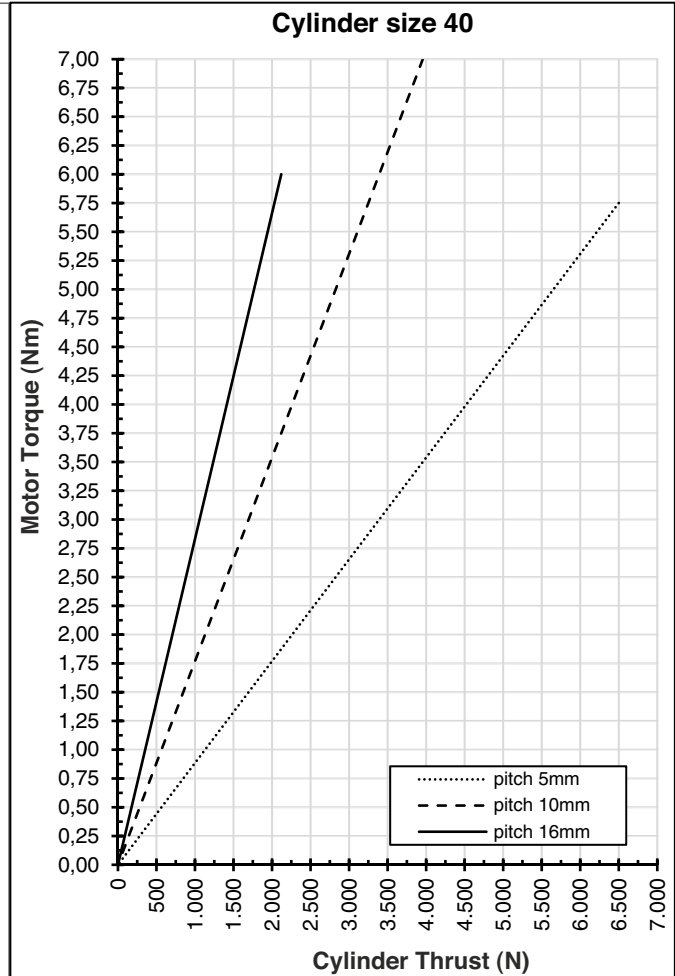
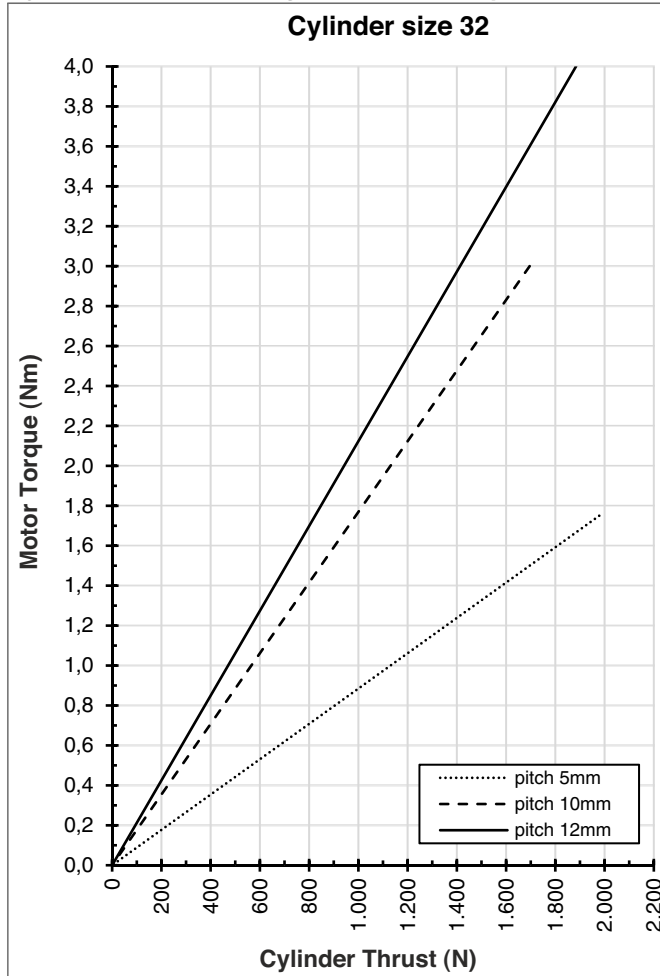



Service life

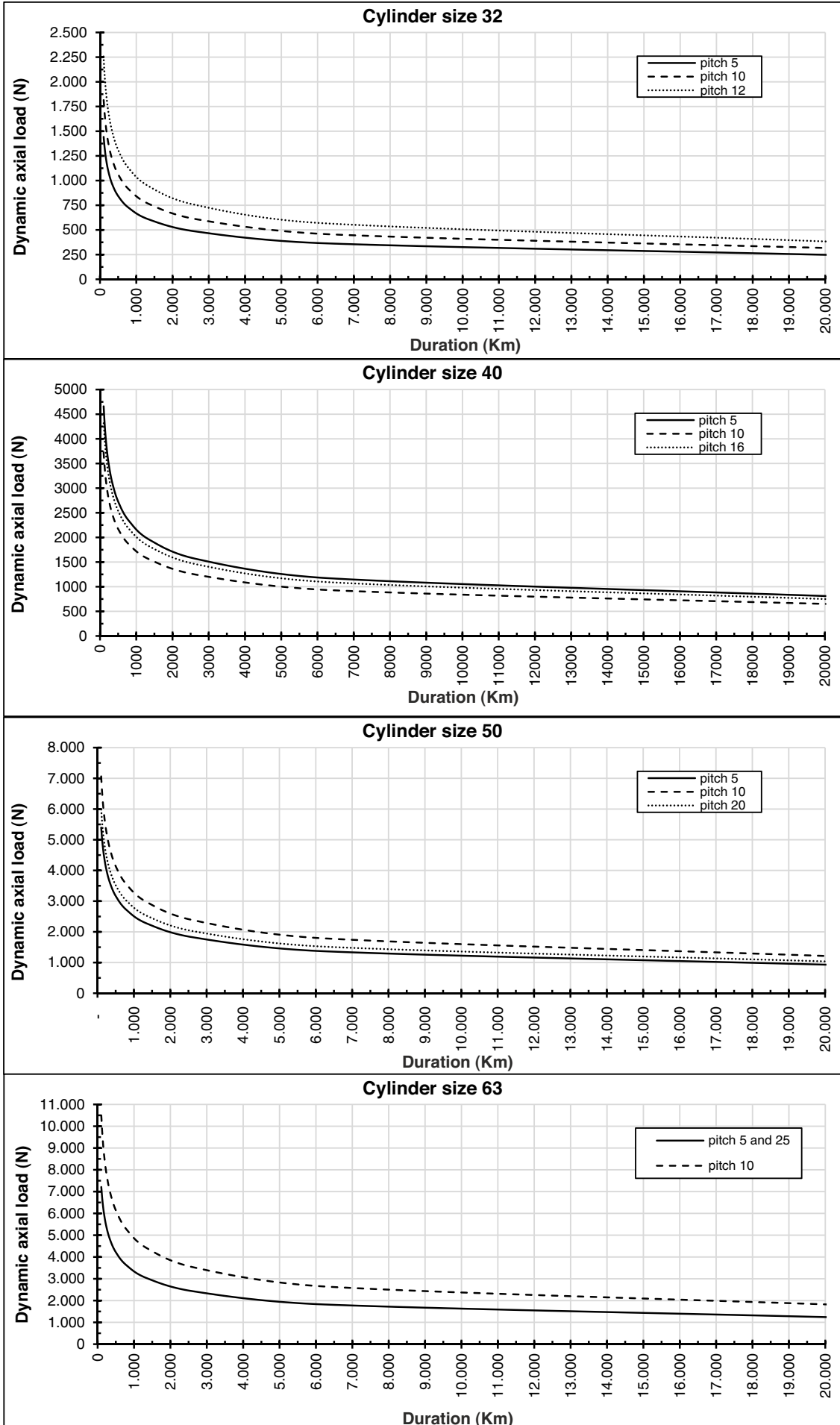

Cylinder fixing

The cylinder fixing interface (mounting holes and piston rod dimensions) conform to the ISO 15552 Standard. Therefore the cylinders can be fixed with:

- the threaded holes (pos.1 and pos.4)
- the thread on the rod (pos.3)
- on the barrel (pos.5 and pos.2)

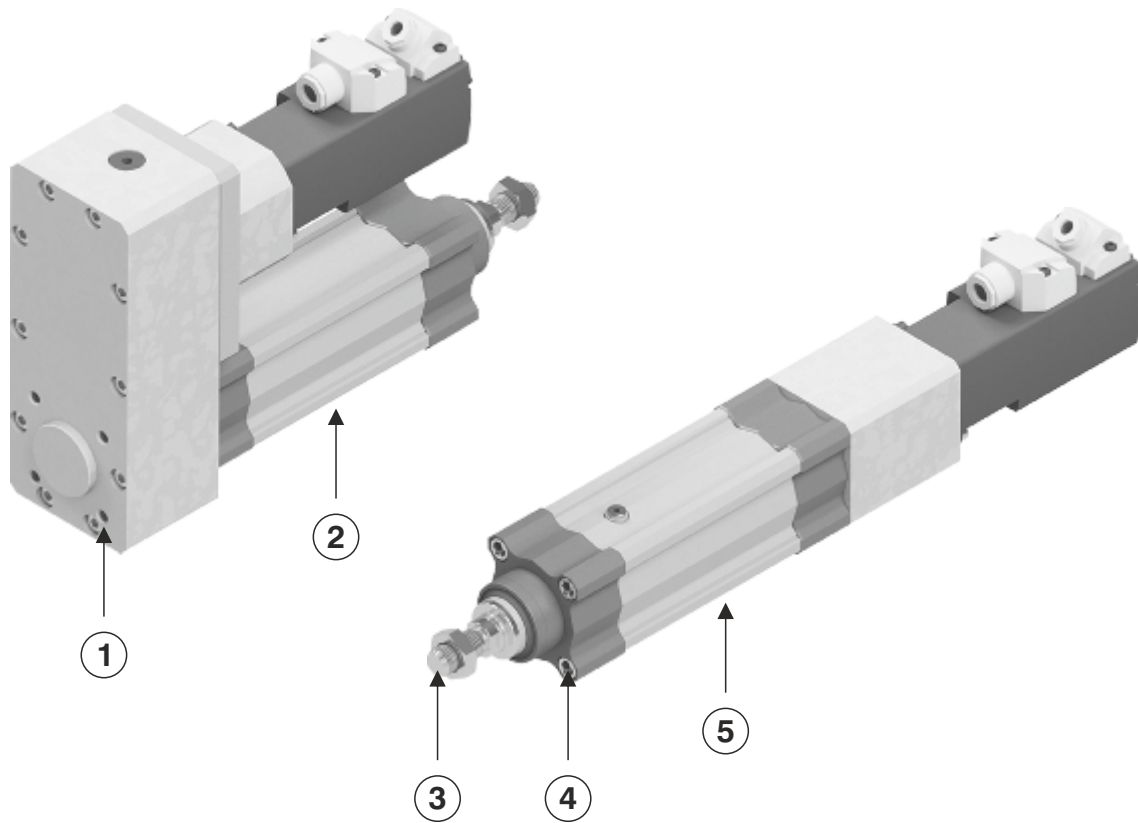

The following page shows all the fixing devices suitable for fixing the cylinders to the in-line or parallel mounted motors.

Fixing devices available

ELECTRICAL IMPLEMENTATION

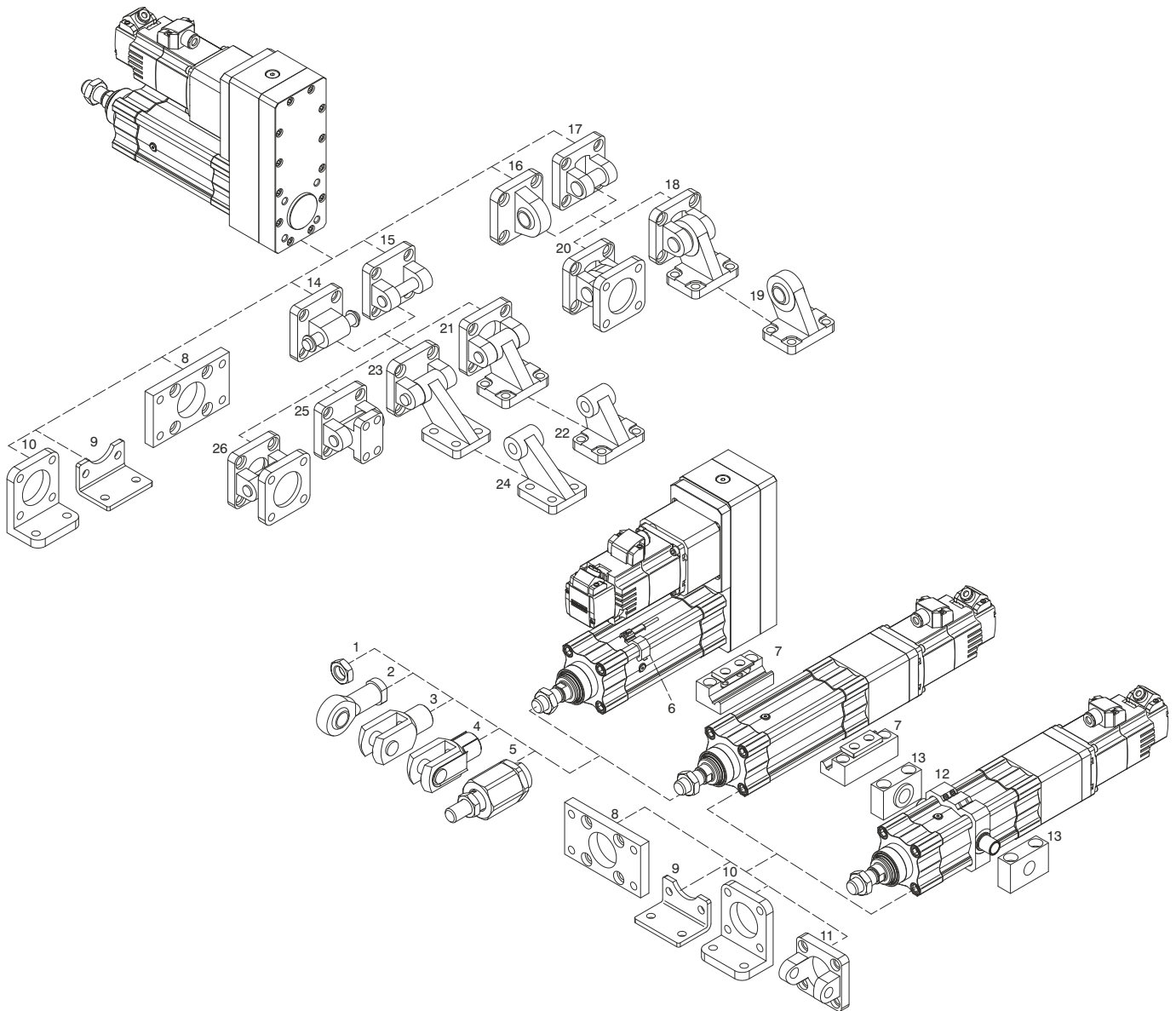

Position	Description	Alluminium	Steel
1	Rod nut	/	1320.Ø.18F
2	Ball joint	/	1320.Ø.32F
3	Fork	/	1320.Ø.13F
4	Fork with clips	/	1320.Ø.13/1F
5	Self-aligning joint	/	1320.Ø.33F
6	Sensor bracket	1320_ S	/
7	Intermediate supports	1800.Ø.02F	
8	Flange (MF1-MF2)	1390.Ø.03FP	1380.Ø.03F
9	Short mounting foot brackets (MS1)	/	1320.Ø.05/1F
10	Short mounting foot brackets	1320.Ø.05F	/
11	Front clevis (not according to standard ISO 15552)	1380.Ø.08F	1320.Ø.19F
12	Intermediate trunnion	1320.Ø.12BF	1320.Ø.12F
13	Support for intermediate trunnion	1320.Ø.12/1F	/
14	Rear male clevis (MP4)	1380.Ø.09/1F	1320.Ø.21F
15	Rear female clevis (MP2)	1380.Ø.09F	1320.Ø.20F
16	Rear male clevis (with jointed head - MP6)	1380.Ø.15F	1320.Ø.25F
17	Rear narrow clevis (AB6)	1380.Ø.30F	1320.Ø.29F
18	Complete square angle trunnion (pos.17+19)	/	1320.Ø.27F
19	Simple square counter clevis	/	1320.Ø.28F
20	Square angle trunnion with jointed head (pos.16+17)	1380.Ø.36F	1320.Ø.26F
21	Square angle trunnion (AB7) (pos.15+22)	1380.Ø.35F	1320.Ø.23F
22	Simple square counter clevis	1320.Ø.11/2F	1320.Ø.24F
23	Simple rear trunnion with support brackets (pos.24+15)	1380.Ø.11F	/
24	Simple square counter clevis	1320.Ø.11/1F	/
25	Standard trunnion	1380.Ø.10F	/
26	Standard complete trunnion (pos.14+15)	1320.Ø.22F	1320.Ø.22F

Front and rear flanges (MF1 - MF2)

Ordering code

Steel : **1380.Ø.03F**
 Aluminium : **1390.Ø.03FP**

Plate which allows anchorage of the cylinder at a right angle to the plane.

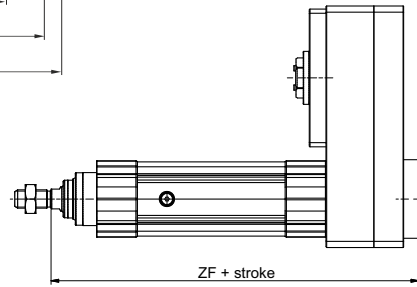
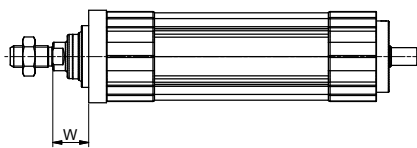
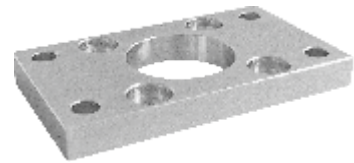
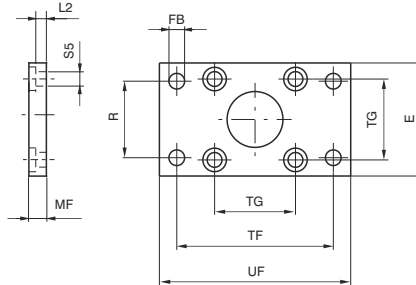

Size	E	FB (H 13)	MF (JS 14)	R (JS 14)	TF (JS 14)	TG	UF	ZF	W	L2	S5	Weight (g) steel	Weight (g) aluminium
32	45	7	10	32	64	32,5	80	171.7	16	5	6,6	190	60
40	52	9	10	36	72	38	90	242.7	20	5	6,6	250	69
50	65	9	12	45	90	46,5	110	291.2	25	6,5	9	480	130
63	75	9	12	50	100	56,5	120	305	25	6,5	9	620	170

Standard mounting foot brackets

Ordering code

Aluminium: **1320.Ø.05F**
 (1 piece)

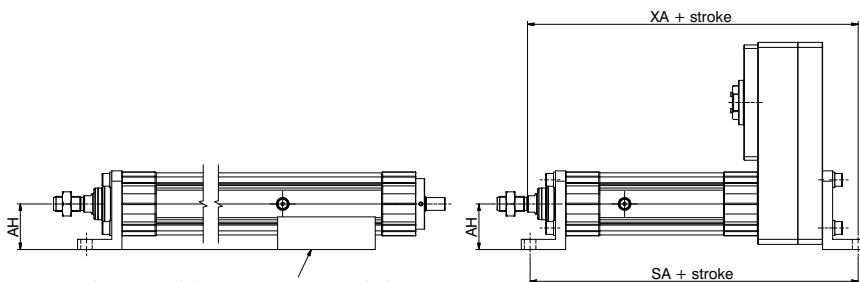
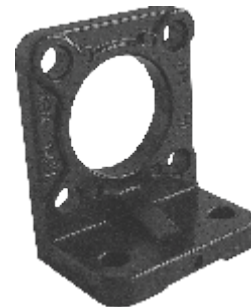
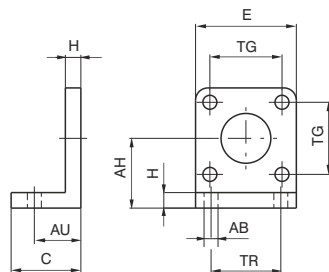

FOR THE VERSION WITH THE IN-LINE MOTOR, IT IS POSSIBLE TO USE THE FOOT MOUNTING BRACKETS BY USING THE INTERMEDIATE SUPPORT 1800.Ø.02F

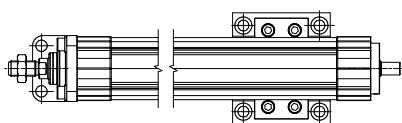

Elements used to anchor the cylinder parallel to the mounting plane. They are made of cast aluminium, painted black.

Size	32	40	50	63
AB (H 14)	7	9	9	9
AH (JS 15)	32	36	45	50
AU (±0,2)	24	28	32	32
C	35	35	45	45
E	45	52	65	75
H	8	8	10	10
SA	228.7	258.7	306.2	320
TG	32,5	38	46,5	56,5
TR (JS 14)	32	36	45	50
XA	230.7	260.7	311.2	325
Weight (g)	45	65	140	175

Short mounting foot brackets (in sheet metal MS1)

Ordering code

Steel: **1320.Ø.05/1F**
(1 piece)

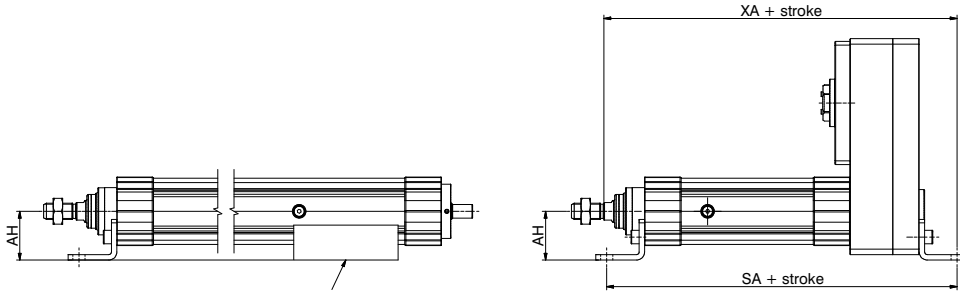
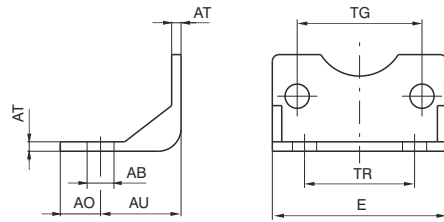

FOR THE VERSION WITH THE IN-LINE MOTOR, IT IS POSSIBLE TO USE THE FOOT MOUNTING BRACKETS BY USING THE INTERMEDIATE SUPPORT 1800.Ø.02F

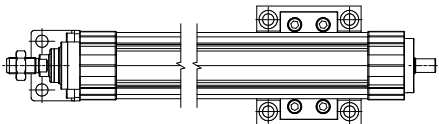

Elements used to anchor the cylinder parallel to the mounting plane. They are made of steel, and painted black.

Size	32	40	50	63
AB (H 14)	7	9	9	9
AH (JS 15)	32	36	45	50
AU (± 0.2)	24	28	32	32
AO (± 0.2)	11	8	15	13
E	45	52	65	75
AT	4	4	5	5
SA	228.7	258.7	306.2	320
TG	32,5	38	46,5	56,5
TR (JS 14)	32	36	45	50
XA	230.7	260.7	311.2	325
Weight (g)	65	80	170	190

Front clevis (not specified by ISO-VDMA standards)

Ordering code

Aluminium: **1380.Ø.08F**
Steel: **1320.Ø.19F**

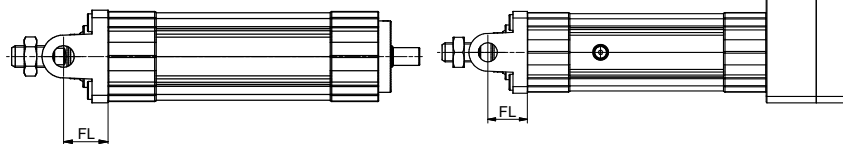
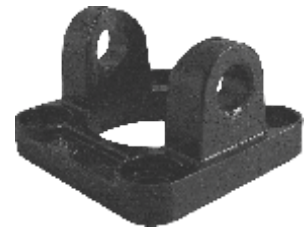
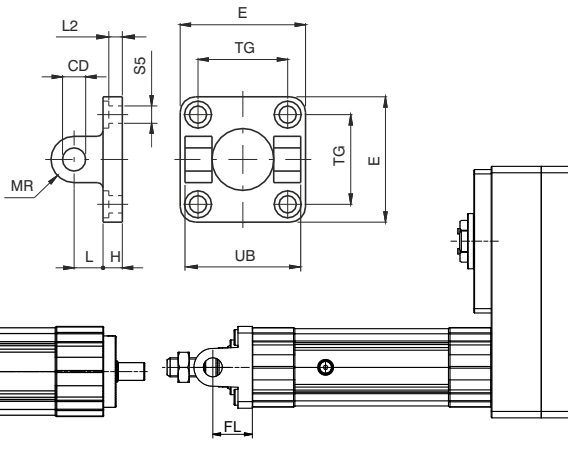

Used to mount the cylinder either parallel or at a right angle to the mounting plane; allows the cylinder to self-align under load. Made of aluminium alloy or steel (see ordering code) and painted black.

Size	32	40	50	63
CD (H9)	10	12	12	16
E	Aluminium	45	52	65
	Steel	45	55	65
FL (±0,2)	22	25	27	32
H	Aluminium	9	9	11
	Steel	10	10	10
L	Aluminium	13	16	16
	Steel	12	15	17
MR	10	12	12	16
TG	32,5	38	46,5	56,5
UB (h14)	45	52	60	70
L2(±0,5)	5,5	5,5	6,5	6,5
S5 (H13)	6,6	6,6	9	9
Weight (g)	Aluminium	50	75	125
	Steel	150	235	340

Rear clevis (MP2)

Ordering code

Aluminium: **1380.Ø.09F**
Steel: **1320.Ø.20F**

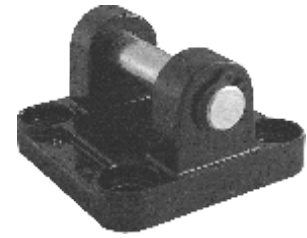
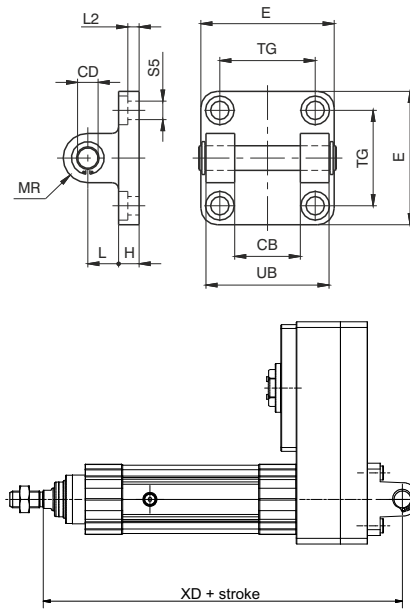

Similar to type 08 but includes a hinge pin. This type of mounting allows anchorage of the cylinder either parallel or right angle to plane; the cylinder rod can oscillate and self-align as necessary when under load. Made of aluminium alloy or steel (see ordering code) and painted black.

Size		32	40	50	63
CB (H 14)		26	28	32	40
CD		10	12	12	16
E	Aluminium	45	52	65	75
	Steel	45	55	65	75
H	Aluminium	9	9	11	11
	Steel	10	10	10	12
L	Aluminium	13	16	16	21
	Steel	12	15	17	20
MR		10	12	12	16
TG		32,5	38	46,5	56,5
UB (h14)		45	52	60	70
XD		228.7	257.7	306.2	325
L2(±0,5)		5,5	5,5	6,5	6,5
S5		6,6	6,6	9	9
Weight (g)	Aluminium	80	130	185	310
	Steel	180	290	400	670

Rear male clevis (MP4)

Ordering code

Aluminium: **1380.Ø.09/1F**
Steel: **1320.Ø.21F**

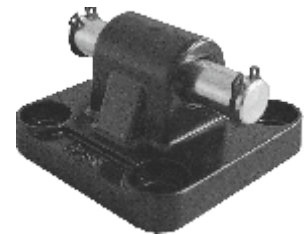
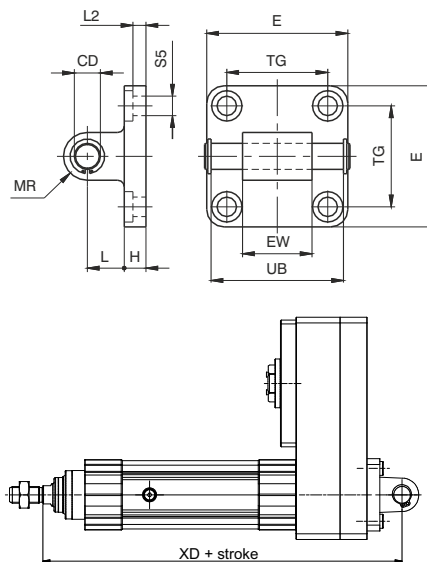

Similar to 09 and 20F clevis except for the connection, which is male rather than female. Used to mount the cylinder either parallel or at a right angle to the plane; the cylinder rod can oscillate and self-align as necessary when under load. Made of aluminium alloy or steel (see ordering code) and painted black.

Size		32	40	50	63
CD		10	12	12	16
E	Aluminium	45	52	65	75
	Steel	45	55	65	75
EW		26 ^(+0,2) _(-0,6)	28 ^(+0,2) _(-0,6)	32 ^(+0,2) _(-0,6)	40 ^(+0,2) _(-0,6)
H	Aluminium	9	9	11	11
	Steel	10	10	10	12
L	Aluminium	13	16	16	21
	Steel	12	15	17	20
MR		10	12	12	16
TG		32,5	38	46,5	56,5
UB (^{0,5})		46	53	61	71
XD		228.7	257.7	306.2	325
L2 (±0,5)		5,5	5,5	6,5	6,5
S5		6,6	6,6	9	9
Weight (g)	Aluminium	90	130	190	340
	Steel	210	330	430	810

Simple rear trunnion with support brackets (not specified by ISO-VDMA standards)

Ordering code

Aluminium: **1380.Ø.11F**
Counter clevis can be ordered separately with code 1320.Ø.11/1F

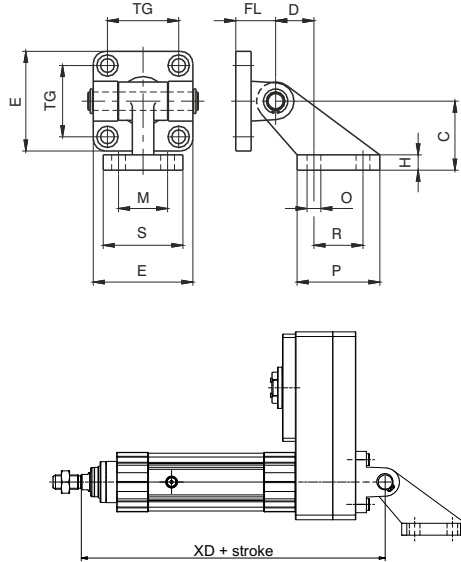

Size	32	40	50	63
C (±0,2)	32	45	45	63
D (±0,5)	18	25	25	32
E	45	52	65	75
H	8	10	10	12
FL	22	25	27	32
M (JS 14)	25	32	32	40
TG	32,5	38	46,5	56,5
O (H 13)	7	9	9	11
P	37	54	54	75
R (JS 14)	20	32	32	50
S	41	52	52	63
XD	228.7	257.7	306.2	325
Weight (g)	130	260	330	600

Used to mount cylinders parallel to the plane to which the counter clevis is attached. Allows self-alignment of the cylinder rod under load with an oscillation up to 90 degrees from the mounting plane.

Square angle trunnion

Ordering code

Aluminium: **1380.Ø.35F**
Counter clevis can be ordered separately with code 1320.Ø.11/2F

Steel: **1320.Ø.23F**
Counter clevis can be ordered separately with code 1320.Ø.24F

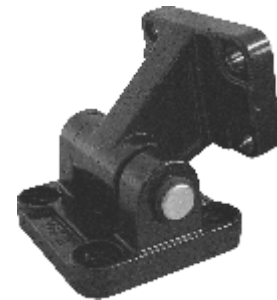
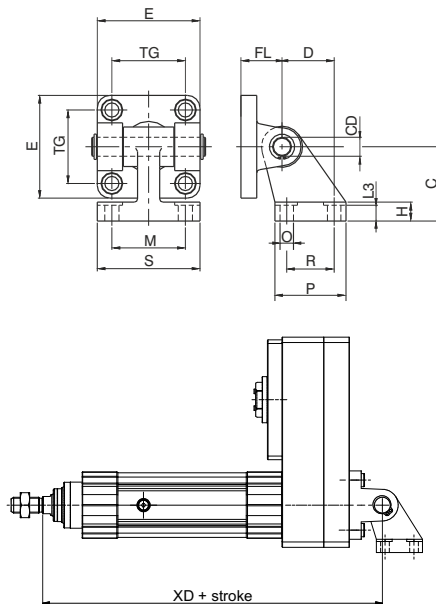

Size		32	40	50	63
E	Aluminium	45	52	65	75
	Steel	45	55	65	75
TG		32,5	38	46,5	56,5
FL		22	25	27	32
D (JS14)		21	24	33	37
CD		10	12	12	16
C (JS15)		32	36	45	50
H	Aluminium	8	10	12	14
	Steel	8	10	12	12
L3	Aluminium	6,4	8,4	10,4	12,4
	Steel	6,5	8,5	10,5	10,5
R (JS14)		18	22	30	35
P		31	35	45	50
O (H13)		6,6	6,6	9	9
S		51	54	65	67
M (JS14)		38	41	50	52
XD		228.7	257.7	306.2	325
Weight (g)	Aluminium	120	180	225	435
	Steel	340	500	640	1250

Standard trunnion (not specified by ISO-VDMA standards)

Ordering code

Aluminium: **1380.Ø.10F**

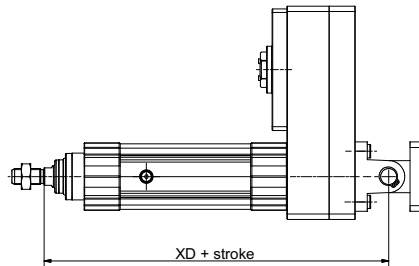
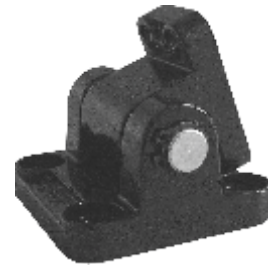
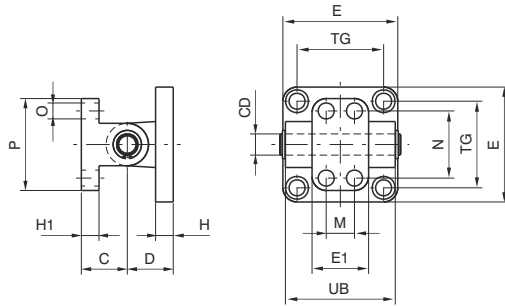

Mounting consists of clevis 09 and counter clevis. Used to mount cylinders at a right angle to the plane to which the counter clevis is attached. Allows self-alignment of the cylinder rod under load with an oscillation of ± 60 degrees.

Size	32	40	50	63
C (± 0.2)	18	26	26	34
CD	10	12	12	16
D	22	25	27	32
E	45	52	65	75
E1	25	32	32	46
H	10	10	12	12
H1	8	10	10	12
M (± 0.2)	-	16	16	25
N (± 0.2)	28	38	38	54
O	7	9	9	11
P	40	52	52	75
TG	32.5	38	46.5	56.5
UB	45	52	60	70
XD	228.7	257.7	306.2	325
Weight (g)	110	190	240	490

Rear narrow clevis

Ordering code

Aluminium: **1380.Ø.30F**
Steel: **1320.Ø.29F**

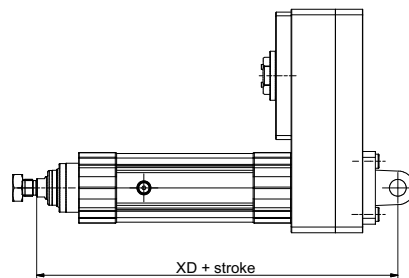
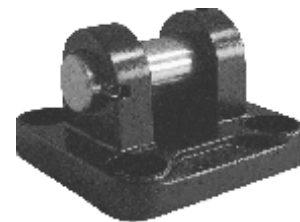
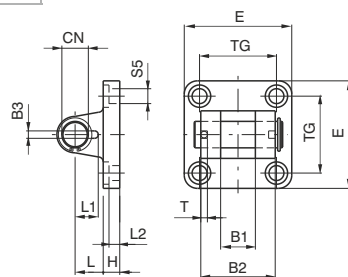

Utilised with clevis 15F or 25F allows the cylinder to oscillate in all directions. Made of aluminium alloy or steel (see ordering code) and painted black.

Size	32	40	50	63
B1 (H 14)	14	16	21	21
B2 (d 12)	34	40	45	51
B3 ($^{+0.2}$)	3,3	4,3	4,3	4,3
CN	10	12	16	16
E	Aluminium	45	52	65
	Steel	45	55	65
H	Aluminium	9	9	11
	Steel	10	10	10
L	Aluminium	13	16	16
	Steel	12	15	17
L1	11,5	12	14	14
L2 ($\pm 0,5$)	5,5	5,5	6,5	6,5
S5	6,6	6,6	9	9
T	3	4	4	4
TG	32,5	38	46,5	56,5
XD	228,7	257,7	306,2	325
Weigth (g)	Aluminium	70	115	200
	Steel	160	270	370

Rear male clevis (with joined head according to DIN 648K standard)

Ordering code

Aluminium: **1380.Ø.15F**
Steel: **1320.Ø.25F**

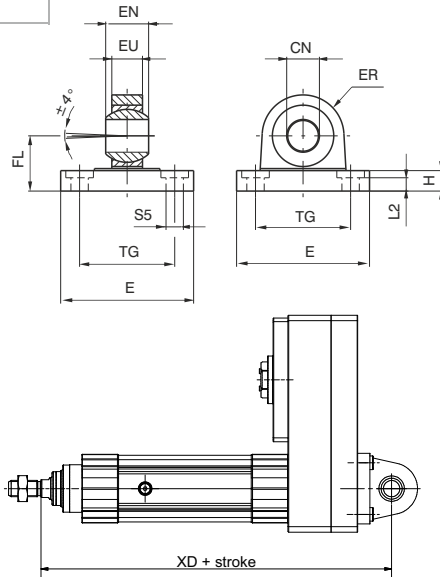

Utilised with clevis 30F or 29F allows the cylinder to oscillate in all directions. Made of aluminium alloy or steel (see ordering code) and painted black.

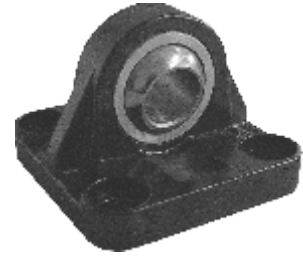

Size		32	40	50	63
CN (H 7)		10	12	16	16
E	Aluminium	45	52	65	75
	Steel	45	55	65	75
EN (-0.1)		14	16	21	21
ER	Aluminium	16	19	21	24
	Steel	15	18	20	23
EU		10.5	12	15	15
FL (JS 15)		22	25	27	32
H	Aluminium	9	9	11	11
	Steel	10	10	10	12
L2 (±0.5)		5.5	5.5	6.5	6.5
S5		6.6	6.6	9	9
TG		32.5	38	46.5	56.5
XD		228.7	257.7	306.2	325
Weight (g)	Aluminium	60	100	180	245
	Steel	210	310	400	710

Complete standard trunnion (with joined head according to DIN 648K standards)

Ordering code

Aluminium: **1380.Ø.36F**
Counter clevis can be ordered separately with code 1380.Ø.15F

Steel: **1320.Ø.26F**
Counter clevis can be ordered separately with code 1320.Ø.25F

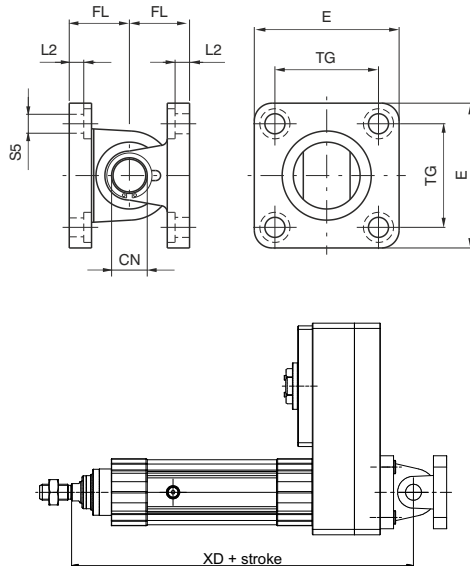

Size		32	40	50	63
CN		10	12	16	16
E	Aluminium	45	52	65	75
	Steel	45	55	65	75
FL (JS 15)		22	25	27	32
L 2 (±0.5)		5.5	5.5	6.5	6.5
S5		6.6	6.6	9	9
TG		32.5	38	46.5	56.5
XD		228.7	257.7	306.2	325
Weight (g)	Aluminium	130	215	380	535
	Steel	380	580	770	1380

Standard complete trunnion

Ordering code

Aluminium: **1380.Ø.22F**

Mounting consists of rear clevis code 1380.Ø.09F
+ rear male clevis code 1380.Ø.09/1F
(ordering separately)

Steel: **1320.Ø.22F**

Mounting consists of rear clevis code 1320.Ø.20F
+ rear male clevis code 1320.Ø.21F
(ordering separately)

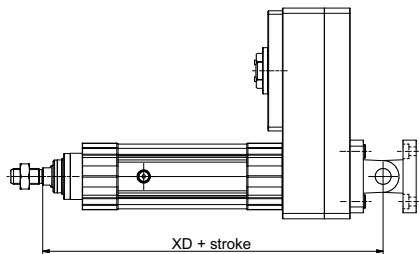
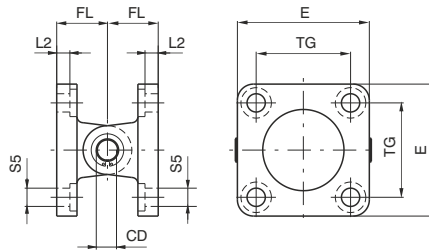

Size	32	40	50	63
CD	10	12	12	16
E	45	55	65	75
FL	22	25	27	32
L 2 (±0.5)	5,5	5,5	6,5	6,5
S 5	6,6	6,6	9	9
TG	32,5	38	46,5	56,5
XD	228.7	257.7	306.2	325
Weight (g)	360	580	780	1370

Complete square angle trunnion (with joined head according to DIN 648K standards)

Ordering code

Steel: **1320.Ø.27F**

Mounting consists of rear clevis narrow code 1320.Ø.29F
+ simple counter clevis code 1320.Ø.28F
(ordering separately)

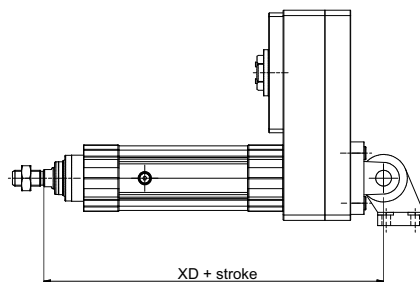
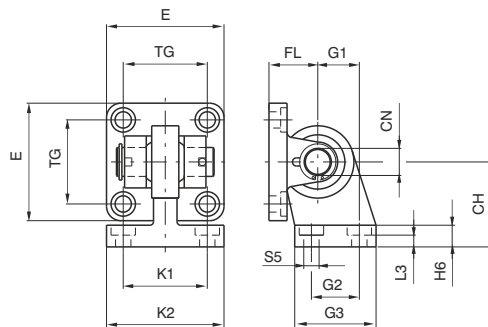

Size	32	40	50	63
CH (JS 15)	32	36	45	50
CN	10	12	16	16
E	45	55	65	75
FL (JS 15)	22	25	27	32
G1 (JS 15)	21	24	33	37
G2 (JS 14)	18	22	30	35
G3	31	35	45	50
H6	10	10	12	12
K1 (JS 14)	38	41	50	52
K2	51	54	65	67
L3 (+0.5/-0)	8,5	8,5	10,5	10,5
S5	6,6	6,6	9	9
TG	32,5	38	46,5	56,5
XD	228.7	257.7	306.2	325
Weight (g)	330	480	830	1220



Intermediate trunnion

Ordering code

Steel: **1320.Ø.12F**

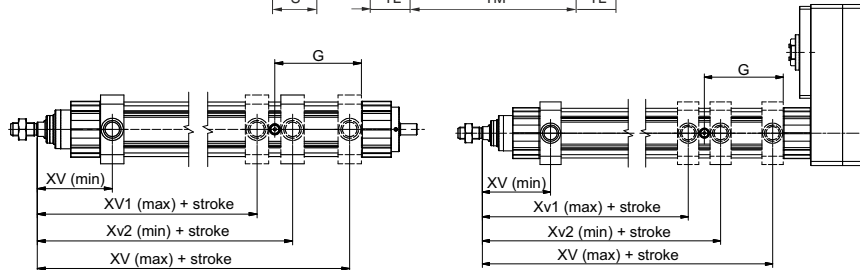
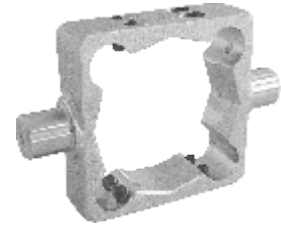
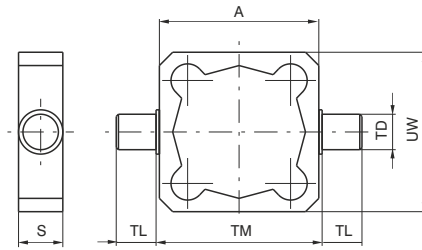

Size	XV (min)	Xv1 (max) + stroke	Xv2 (min) + stroke	XV (max) + stroke	G position of lubrication point (mm)
32	61	62.5	92.5	119.5	60
40	69	72	105	145.5	78
50	78	84.5	117.5	166	86
63	86	95.5	134.5	182	94

Minimum Cylinder Stroke: 30mm (In addition to stroke required)

Clevis to be mounted on the barrel to have the centre of rotation of the hinge pin at a point between the end plates of the cylinder. It is attached to the barrel by means of eight pointed grains that block in the "V" groove of the four protruding shapes. In the case of anchorage subject to heavy use, it is recommended to connect the clevis once the right position has been found.

Attention: mounting of the clevis with contact to the end plates does not allow the use of the magnetic sensors as the switch limits.

Size	32	40	50	63
A	49	62	73	87
S	18	21	21	27
TD (e9)	12	16	16	20
TL (h14)	12	16	16	20
TM (h14)	50	63	75	90
UW	59	62	73	87
Weight (g)	180	270	330	650

Intermediate trunnion

Ordering code

1320.Ø.12BF
(Aluminium with steel bushes)

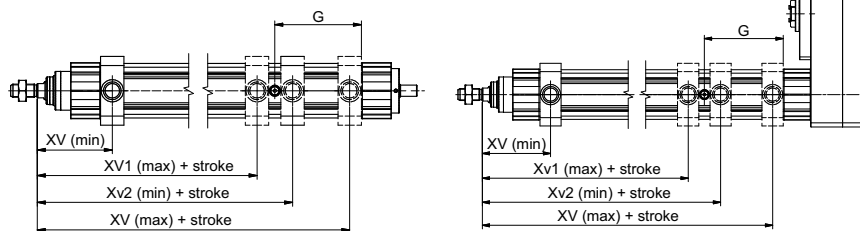
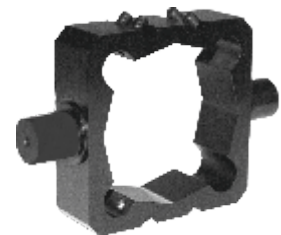
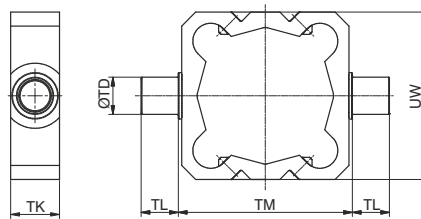

Size	XV (min)	Xv1 (max) + stroke	Xv2 (min) + stroke	XV (max) + stroke	G position of lubrication point (mm)
32	61	62.5	92.5	119.5	60
40	69	72	105	145.5	78
50	78	84.5	117.5	166	86
63	86	95.5	134.5	182	94

Minimum Cylinder Stroke: 30mm (In addition to stroke required)

Aluminium Intermediate Trunnion with steel bushes to be mounted on the barrel. This solution allows the cylinder to rotate around the hinge which can be mounted in any position between the end caps. It is attached to the barrel by means of 8 grub screws which secure the Trunnion to the extruded barrel. In the case of heavy duty applications it is recommended that the Trunnion is secured using expansion pins. In case of applications with high speed, high load and high pressure please contact our technical office.

Please note: If the Trunnion is mounted in direct contact with the cylinder end cap, it will not be possible to fit magnetic sensors at the end of stroke.

Size	32	40	50	63
TD	Ø12	Ø16	Ø16	Ø20
TL	12	16	16	20
TM	50	63	75	90
TK	18	21	21	27
UW	54	60	72	87
Weight (g)	70	110	140	280

Support for intermediate trunnion

Ordering code

1320.Ø.12/1F
(1 piece)

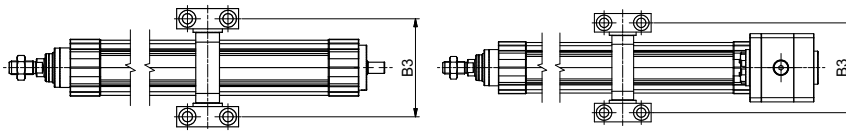
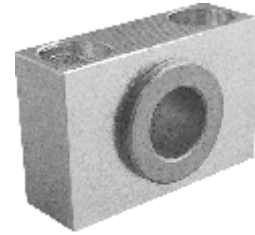
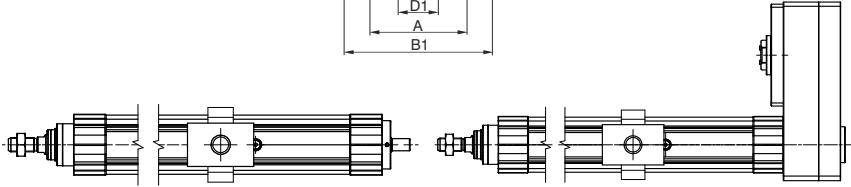
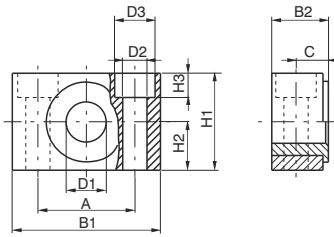

Size	32	40	50	63	80
A (± 0.2)	32	36	36	42	42
B1	46	55	55	65	65
B2	18	21	21	23	23
B3	71	87	99	116	136
C	10.5	12	12	13	13
D1 (F7)	12	16	16	20	20
D2	6.6	9	9	11	11
D3	11	15	15	18	18
H1	30	36	36	40	40
H2 (± 0.1)	15	18	18	20	20
H3	7	9	9	11	11
Weight (g) (1 piece)	100	150	150	235	235

Combining two supports to the intermediate trunnion it is possible to fix the cylinder on plane surface.

Intermediate support

Ordering code

1800.Ø.02F
(2 pieces)

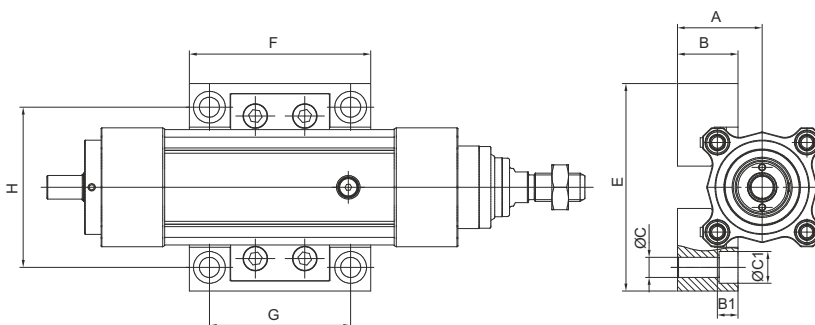

Number of supports for application

Size	Stroke	
	≤ 100	> 100
32	≤ 80	> 80
40	≤ 70	> 70
50	≤ 55	> 55
63	1	2

Size	32	40	50	63
A	32	36	45	50
B	25	26	31,5	31,5
B1	8	8	8	8
C	8.5	8.5	9	9
ØC1	13.5	13.5	14	14
D	60	68	81,5	91,5
E	82,5	88	102	111,5
F	77	77	77	77
G	60	60	60	60
H	60	68	81,5	91,5
Weight (g)	313	331	391	391

Attention: fixing not available on the following cylinders:
Size 40, with motor Part No. 1800B0801900 online
Size 50, with motor Part No. 1800B1001900 online
Maximum axial thrust per single support (With screws tightened to 20Nm):
Ø32 = 1950N - Ø40 = 6550N - Ø50 = 7400N - Ø63 = 7400N



Rod forks and nuts

Ordering code	
1320.Ø.13F	
1320.Ø.13/1F	
1320.Ø.18F	

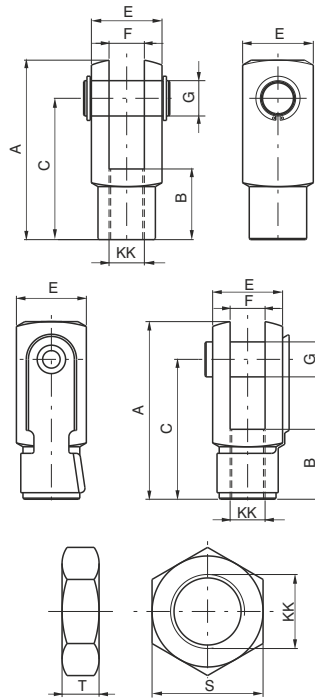

Fork:

Element that when screwed to the rod consents a regular functioning even when there are significant lateral forces as the connection point. Made of zinc-plated steel.

Nut:

Used to block the position of the fork.

Size	32	40	50	63	
A	52	62	83	83	
B	20	24	32	32	
C	40	48	64	64	
E	20	24	32	32	
F(B12)	10	12	16	16	
G	10	12	16	16	
S	17	19	24	24	
T	6	7	8	8	
KK	M10X1.25	M12X1.25	M16X1.5	M16X1.5	
Peso (g)	forcella	100	140	340	340
	dado	15	20	20	20

Lubrication Filling Syringe

Ordering code	
1400.99.02	

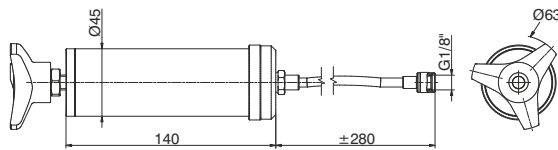

Weight (g) 420

For the amount of lubricant and re-fill interval, please refer to the assembly instructions

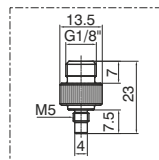

Lubrication (Grease)

Ordering code	
RS/GRAS19	

For the Ball screws, please use the lubricant (Grease) specified

Weight (g) 1.000

Ball joint

Ordering code

1320.Ø.32F

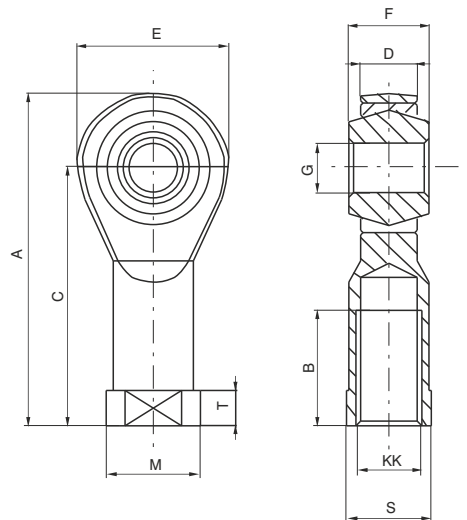

Size	32	40	50	63
A	57	66	85	85
B	20	22	28	28
C	43	50	64	64
D (-0.1)	10.5	12	15	15
E	28	32	42	42
F	14	16	21	21
G (H 7)	10	12	16	16
KK	M10x1.25	M12x1.25	M16x1.5	M16x1.5
M	19	22	27	27
S	17	19	22	22
T	6.5	6.5	8	8
Weight (g)	76	110	220	220

Self-aligning joint

Ordering code

1320.Ø.33F

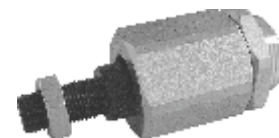
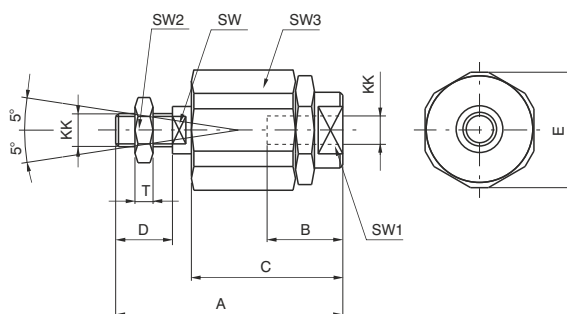

Size	32	40	50	63
A	71	75	103	103
B	20	20	32	32
C	46	46	63	63
D	20	24	32	32
E	32	32	45	45
KK	M10x1.25	M12x1.25	M16x1.5	M16x1.5
SW	12	12	20	20
SW1	19	19	27	27
SW2	17	19	24	24
SW3	30	30	41	41
T	6	7	8	8
Weight (g)	220	230	660	660

Magnetic Sensors (Limit Switches)

Accidental collision of a mechanical limit switch can cause damage the electric cylinder. Therefore it is advisable to use magnetic sensor limit switches. (Important: Avoid external magnetic interference near the sensors.

You can use REED or HALL effect sensors. For the types available, see following pages.

The limit switches must be fixed to the cylinder barrel profile using the appropriate aluminum mounting brackets indicated below.

ELECTRICAL IMPLEMENTATION

Sensor brackets 1580._, MRS._, MHS._		
Code	Size	L1
1320.AS	32	48
	40	54
1320.BS	50	66
	63	76

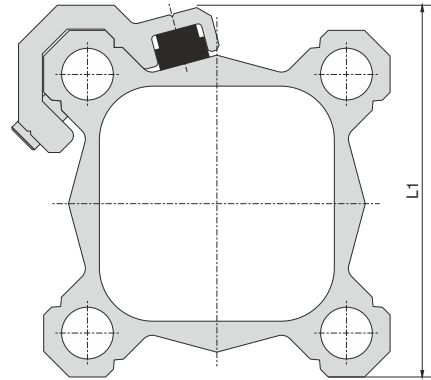

Assembly

Remove the screw as shown on **pos.1** and attached to the bracket as shown in **pos.2**
attach the switch/bracket on to the barrel in the required position and fix with the screw a shown on **pos.3**.

There after, check that the function of the switch is correct and is in the correct position byoperating the actuator slowly.
This will help avoid damage to the cylinder because of incorrect switch position.
The Homing search phase must be performed at low speed (close to 10mm/sec) to avoid harmful impacts to the device.

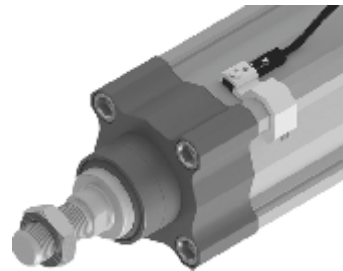
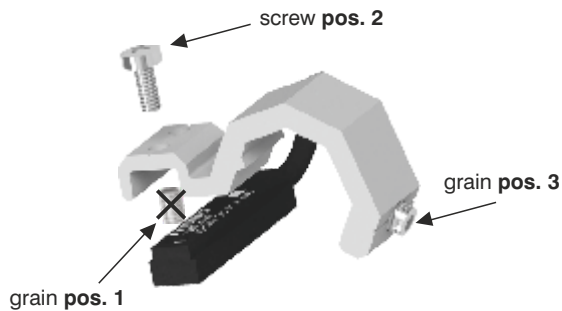

Sensor with 2.5 m. cable



Weight gr. 27

Sensor with cable and M8 connector



Weight gr. 15

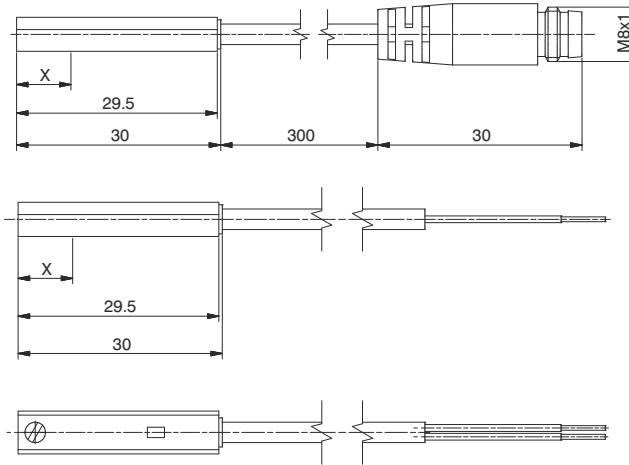

X= point of commutation

Sensor ordering codes

Ampulla Reed sensors, with led, Universal, N.O. (Normally open)		X=point of commutation
1580.U	(2 wires) cable 2.5 mt.	15 mm
MRS.U	(2 wires) cable 300 mm, M8 connector (use MC1 or MC2 connectors)	15 mm
1580.UAP	PNP (3 wires) cable 2.5 mt.	15 mm
MRS.UAP	PNP (3 wires) cable 300 mm, M8 connector (use MCH1 or MCH2 connectors)	15 mm
Hall effect sensors, with led, DC, N.O. (Normally open)		X=point of commutation
1580.HAP	PNP (3 wires) cable 2.5 mt.	8 mm
1580.HAN	NPN (3 wires) cable 2.5 mt.	8 mm
MHS.P	PNP (3 wires) cable 300 mm, M8 connector (use MCH1 or MCH2 connectors)	8 mm

Diagrams and connections

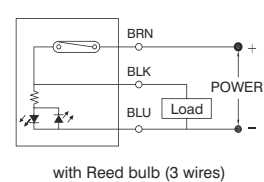
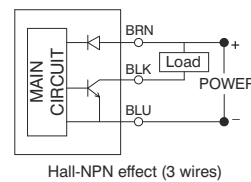
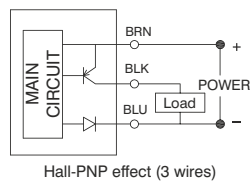
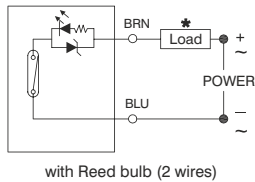

* The load (LOAD) can be connected either to negative or positive pole

Technical characteristics	1580.U	MRS.U	1580.UAP	MRS.UAP	1580.HAP	1580.HAN	MHS.P
Type of contact	N.O.						
Output type				PNP		NPN	PNP
Maximum current				100mA			
Maximum permanent power	14 VA - 10 W			4 VA - 3 W		3 W	
Voltage range	5 - 230V DC/AC	5 - 30V DC/AC	10 - 30 V DC/AC		10 - 30 V DC		
Working temperature	-10°C - +70°C						
Maximum voltage drop	3.5 V			0V **		2 V	
Cable section (mm ²)	2 x 0.14 Ø3.3mm PUR	2 x 0.14 Ø3.3mm PUR	3 x 0.14 Ø3.3 mm PUR		3 x 0.14 Ø3.3 mm PUR		
Degree of protection	IP 67						

** Even if one sensor generates a voltage drop very close to 0 Volts, we suggest to connect no more than 30 sensors in series.

Cable ordering code

Connection 2 wires

- MC1** cable 2 wires l=2.5m with M8 connector
- MC2** cable 2 wires l=5m with M8 connector
- MC3** cable 2 wires l=10m with M8 connector

Connector



Sensor



- 1 Brown (+)
- 4 Blue (-)
- 3 Not use

Connection 3 wires

- MCH1** cable 3 wires l=2.5m with M8 connector
- MCH2** cable 3 wires l=5m with M8 connector
- MCH3** cable 3 wires l=10m with M8 connector

Connector



Sensor



- 1 Brown (+)
- 4 Black (signal)
- 3 Blue (-)

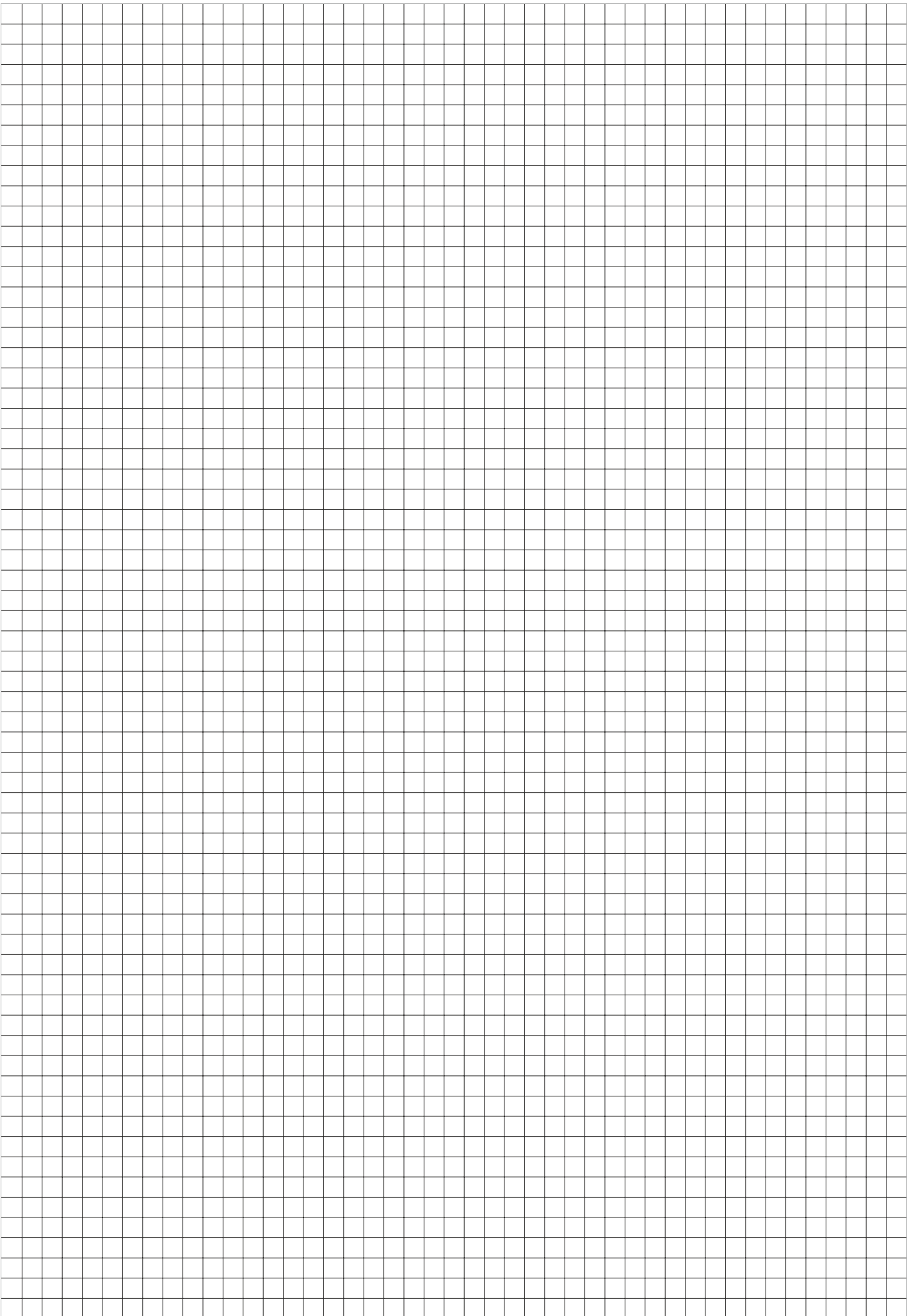

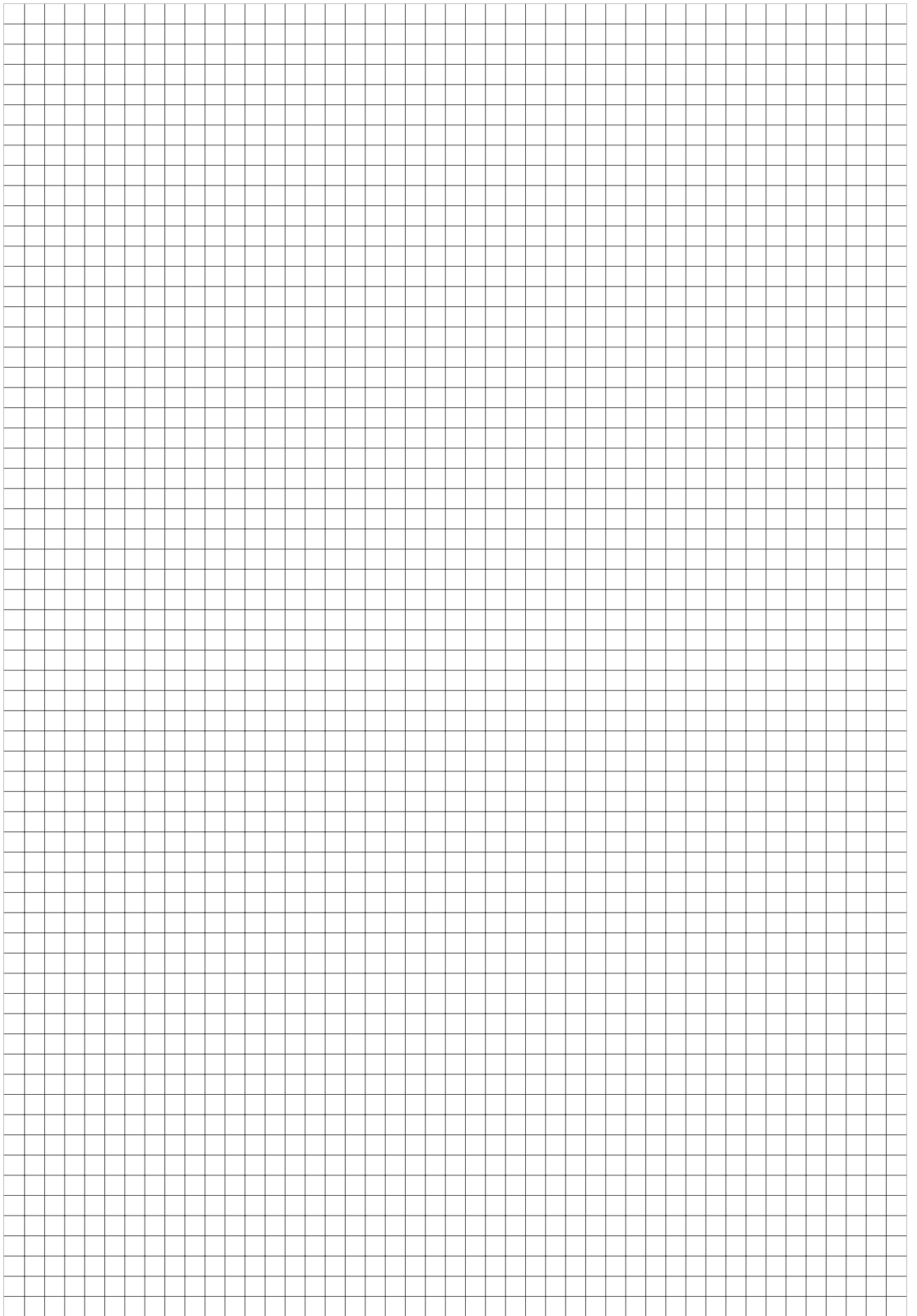

Pneumax S.p.A.

24050 Lurano (BG) Italy
Via Cascina Barbellina, 10

Tel. +39.035.4192777

Fax +39.035.4192741

info@pneumaxspa.com

www.pneumaxspa.com

D.NW.93-GB – 01/2019

PRINTED IN ITALY 01/2019